

# Wien-bridge oscillator with low harmonic distortion

New way of using Wien network to give 0.001% t.h.d.

by J. L. Linsley Hood, Robins (Electronics)

**The Wien-bridge network can be connected in a different way in an oscillator circuit to give a sine wave with very low total harmonic distortion. An i.e.d./photocell amplitude control is external to the circuit.**

The Wien-bridge network remains the most popular method of construction of variable-frequency sine-wave oscillators, since the basic circuit can be very simple in form. It is a fairly straightforward matter to design oscillators of this type in which the harmonic distortion is only of the order of 0.01-0.02%, and which allow frequency control by means of a simple 2-gang potentiometer.

The basic circuit for an oscillator of this form, using a single operational amplifier as the gain block, is shown in Fig. 1, and the author has shown a practical design of oscillator, based on this, for a use as a simple, general-purpose workshop tool.<sup>1</sup> However, in the form shown in Fig. 1, a significant problem exists in that the transmission of a normal Wien network, at the operating frequency, is only 1/3, which means that an inconveniently large proportion of the output signal voltage appears at the inputs of the amplifier, and will lead to non-linearities in the transfer characteristics of the amplifier due to 'common mode' defects. An oscillator design, which employed an input device operated in a cascode configuration with a junction f.e.t. to minimize this type of defect, was shown by the author in 1977,<sup>6</sup> and allowed a t.h.d. at

1kHz of some 0.003%, which tended to increase with frequency above this point, as the effectiveness of the common-mode isolation deteriorated.

However, it is not implicit, in the use of a Wien network as the frequency-control method, that the configuration shown in Fig. 1, in which the output of the network is taken to the non-inverting input of the amplifier and the amplitude controlling negative-feedback signal is taken to the other, is the only circuit configuration which can be employed. In particular, consideration of the phase and transmission characteristics of such a network, shown in Table 1 and Fig. 2 for equal values of C

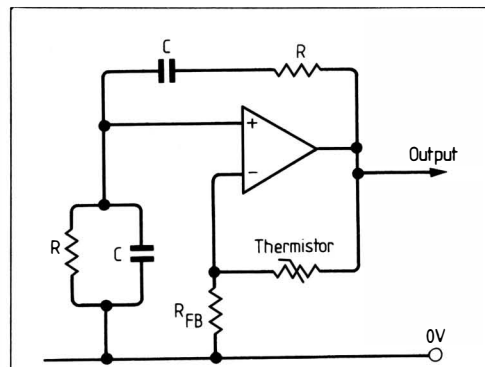

Fig. 1. Basic Wien-bridge oscillator circuit

Fig. 2. Gain and phase characteristics of Wien network

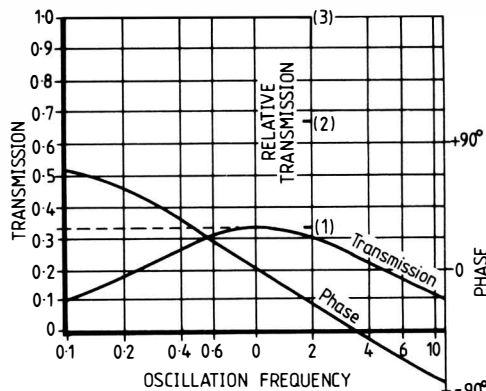
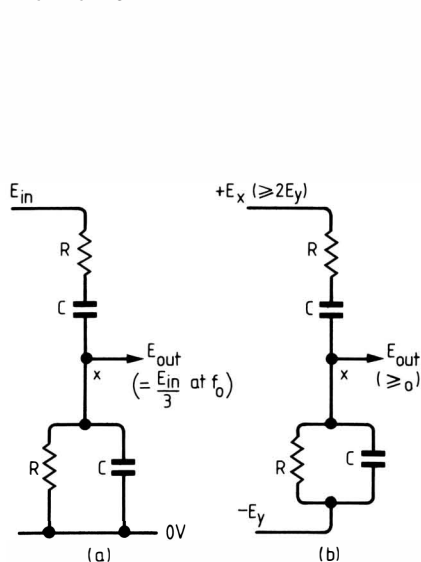
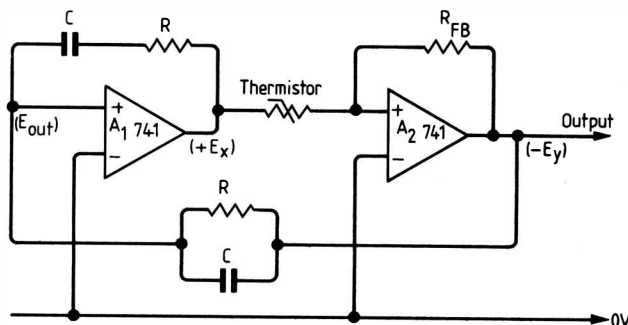

Fig. 3. Rearrangement of Wien network between signal sources gives small in-phase signal at point X

Fig. 4. Use of arrangement of Fig. 3 in oscillator circuit



Figures in brackets refer to diagram 3b

TABLE 1. Phase and transmission characteristics of simple Wien network.

F/F <sub>0</sub>	phase	transmission
0.1	73.14°	0.10
0.2	57.99°	0.18
0.3	45.32°	0.23
0.4	34.99°	0.27
0.5	26.57°	0.30
0.6	19.57°	0.31
0.7	13.65°	0.32
0.8	8.53°	0.33
0.9	4.03°	0.33
1.0	0°	0.33
1.2	-6.97°	0.33
1.5	-15.52°	0.32
2	-26.57°	0.30
3	-41.63°	0.25
5	-57.99°	0.18
8	-69.15°	0.12
10	-73.14°	0.10

and R, implies that if, instead of the network of Fig. 3(a) being connected between a signal source  $E_{in}$  and the 0V line, it was connected between two signal sources  $+E_x$  and  $-E_y$ , where these are sinusoidal and identical in frequency and the negative sign implies phase opposition, as shown in Fig. 3(b), then a small, in-phase signal would exist at the point 'X', at the frequency of maximum transmission, ( $f_0$ ), if  $+E_x$  was slightly greater than  $-2E_y$ .

This could then be used as a positive-feedback signal in a circuit such as that shown in Fig. 4, to sustain oscillation at the frequency  $f_0$ . Indeed, such a circuit will work quite well, and will sustain a constant output magnitude of oscillation if a thermistor is employed, as shown, to make the gain of the second, inverting, amplifier stage dependent on the amplitude of the input signal. However, there is, in practice, a small snag with such an arrangement, and that is that the inverted negative-feedback signal applied to the input of  $A_1$  will suffer an additional phase error due to the internal time lag within  $A_2$ , and this will cause unwanted h.f. instability if '3rd generation' high speed op.-amps. such as the CA 3140, or the 1741 S, are used in the realisation of this circuit.

It is, fortunately, an easy matter to resolve this difficulty if the circuit is recast in the form shown in Fig. 5, in which the negative-feedback signal, equivalent to  $-E_y$  in Fig. 3(b), is derived from the amplifier  $A_1$ , and the positive-feedback signal is obtained from the output of the second inverting amplifier  $A_2$ .

This configuration offers several significant advantages.

- The input signal to  $A_1$  is extremely small, since it is only required to be  $E_{out}/2M$ , where  $M$  is the open-loop gain of  $A_1$  - typically 100dB for a good modern op.amp. i.c. - and, as pointed out by the author in an earlier article<sup>2</sup>, with semiconductor amplifiers the non-linearity of such devices is essentially an input characteristic, dependent on the magnitude of the input signal.
- The second-stage amplifier is operated as a shunt-feedback element, and the non-linearities of such a stage can be shown to

be significantly lower, because of the very small input-signal amplitude and the absence of any internal transfer errors between the inverting and non-inverting inputs, than is the case for an identical amplifying element in a series-feedback configuration.<sup>3,4</sup>

- The time-delay errors in the second amplifying stage ( $A_2$ ) no longer contribute to loss of stability in the system, but only to a very small compensatory shift in the

operating frequency of the oscillator. Fast response-speed, high h.f. gain op.-amps. can therefore be used without problems.

For these reasons, it can be expected that the residual harmonic distortion of this oscillator design will be exceedingly small, and measurements on two prototypes have indeed shown this to be the case. So far as can be determined, the residual distortion - almost exclusively

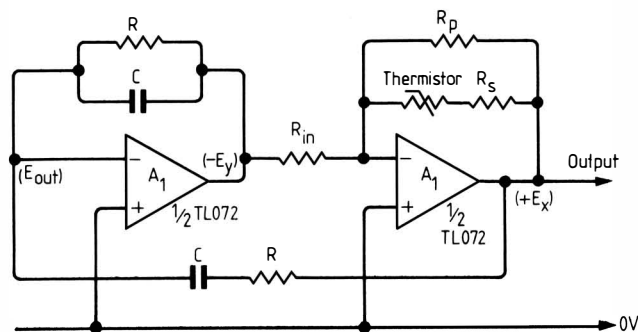

Figures in brackets refer to diagram 3b

$R_p, R_s$  and  $R_{in}$  chosen to suit individual thermistor employed

Fig. 5. Final form of new configuration in low-distortion oscillator

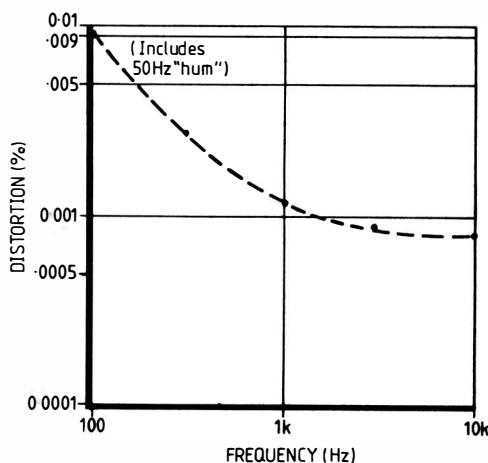
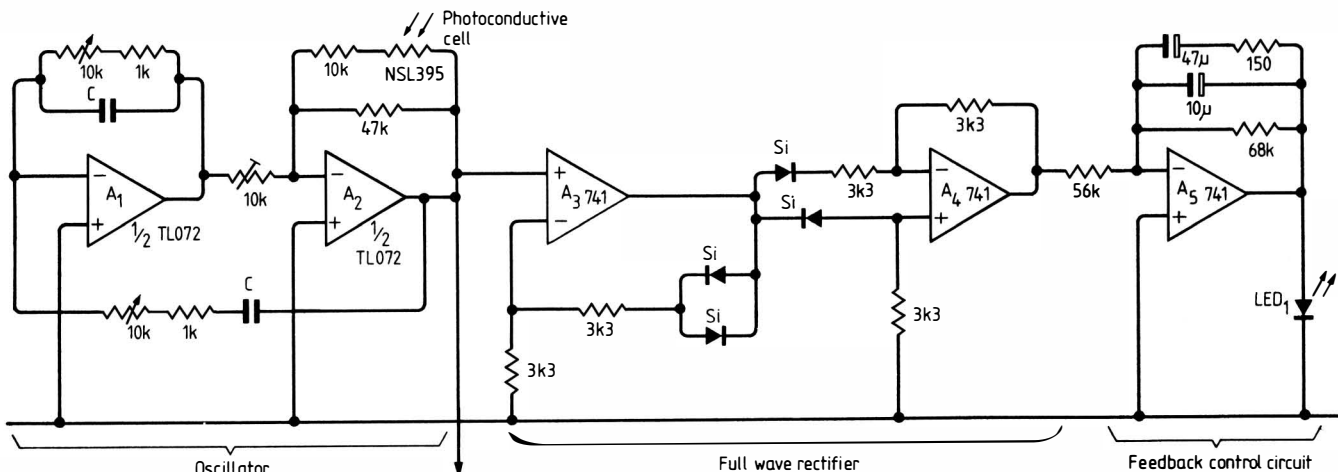

Fig. 6. Measured total harmonic distortion of improved oscillator of Fig. 5

Fig. 7. New oscillator with external optoelectronic amplitude-control circuit. Silonex (formerly National Semiconductors) cell, Type NSL395, is obtainable from Cheston Electronics Ltd., Vanguard House, 56 Oughton Street, Ormskirk, Lancs. Tel: 0695 72456



Note: PC<sub>1</sub> and LED<sub>1</sub> are in optical contact

third harmonic – is that due to the dependence of the resistance of the thermistors used to control the amplitude of the oscillation on the instantaneous value of the signal potential applied to them. This characteristic of oscillators with averaging control systems has been analysed by Robinson<sup>5</sup> who suggests that the distortion of such a system, which is shown to be mainly third harmonic, will be

$$\frac{x_3}{x_1} \approx \frac{1}{8\eta} \cdot \frac{A_0 - \eta}{\eta} \cdot \frac{1}{2\pi f T}$$

where  $(A_0 - \eta)/\eta$  is the fraction by which the low-level loop gain exceeds the gain required to initiate oscillation, and  $T$  is the time constant of the control system (thermistor or similar). In the case of a Wien-bridge oscillator,  $\eta = 3$ .

This equation indicates that if the feedback amplitude is very little above that required to sustain oscillation – which is implicit in the design – the residual distortion will be dependent on the time constant of the control mechanism. By the use of series and parallel resistors of appropriate values with the thermistor, this can be made to control the amplitude of the oscillation at a resistance value which is only a little less than its room-temperature value. Under these circumstances, the settling time of the amplitude is long – perhaps 3-4 seconds at 1kHz, but the t.h.d. will be very low. The penalty incurred in this type of adjustment, apart from the obvious inconvenience of a relatively long settling time following any disturbance, is that the two gangs of the potentiometer used to control the operating frequency of the oscillator must be reasonably well matched in resistance value across the adjustment range, and also, if switched capacitors are used to provide step changes in frequency sweep, the ratios of their values must remain the same.

However, this is merely a statement of the obvious, that it is a pointless exercise to try to design high-performance equipment using low-performance components. Nevertheless, within the limitations imposed by the use of a thermistor as the stabilizing element, the performance of a very simple oscillator, built around a dual operational amplifier (a Texas Instruments TL072), is very good, as is shown in Fig. 6. The total harmonic distortion from this arrangement, in which the resistors associated with the thermistor were adjusted to give a settling time of 5 seconds at 1 kHz, and an output voltage of 2 volts r.m.s., is lower than that obtainable from any other simple Wien-bridge oscillator (that is to say with the exception of systems with low-pass output filtering) known to the author. This distortion is almost exclusively third harmonic – decreasing with frequency – which implies that the source of this waveform distortion is the instantaneous change in gain of the system, during the excursion of each half sinusoid, due to the limited thermal inertia of the thermistor.

The very high performance obtainable from such a circuit encourages the consideration of alternative methods of amplitude control such as that employing a

photo-conductive cell and the light-emitting diode combination shown in Fig. 7, in which the time constant and other dynamic characteristics of the control circuit can be optimized by a suitable combination of proportional, integral and differential (p.i.d.) adjustment to the gain of the control circuit ( $A_2$ ). Needless to say, the photoresistive element should be chosen to have a very low voltage coefficient of resistance and an adequate response speed to avoid the introduction of a further significant time delay into the control loop.

Leaving aside the question of the means employed to control the amplitude of the output signal (which imposes limitations of an identical kind on any oscillator system, in terms of the settling time, and the influence of the control time constant on the harmonic distortion at any given frequency) the improvement in performance given by the circuit design shown in Fig. 5 over that obtainable from the more conventional arrangement shown in Fig. 1, suggests that it would be sensible to regard the improved circuit as a general replacement for the earlier system in all future designs.

#### References.

1. Linsley Hood, J. L., *Hi-Fi News and Record Review*, March 1975, pp 63-67.
2. Linsley Hood, J. L., *Wireless World*, Sept. 1971, p 437.
3. Linsley Hood, J. L., *Wireless World*, Jan. 1973, pp 11-12. www.keith-snook.info
4. Taylor, E. F., *Wireless World*, April 1973, p 194.
5. Robinson, F. N. H., *Intl. J. Electronics*, No. 2 pp 137-148. (1980)
6. Linsley Hood, J. L., *Wireless World*, Sept. 1977, pp 40-42 □

## The impact of new technology at work

More than £90,000 is being made available over three years by two research councils for studies into the shop-floor impact of the introduction of new technology.

Three studies are planned: on telephone exchange modernisation; on the adoption of a computer-based freight information system in British Rail; and on the introduction of electronic news gathering (ENG) equipment in television.

The Science and Social Science Research Councils are sponsoring the work which will be carried out by the New Technology Research Group of Southampton University. The Group has been formed by engineers and social scientists committed to interdisciplinary research "on the introduction of new electronic and computer technologies at the level of the individual workplace".

The two main objectives of the work will be to explore the process of technological change and to develop interdisciplinary research methods for the problems that arise. The team will be investigating the nature of technological innovation and engineering decision-making in the economic and social context of business organisations; the bearing of organisational structures on the capacity of managers to generate methods and mechanisms for the introduction and control of new technology; the development of union strategies towards new technology; the consequences of technological change for the nature of work and occupations; and the effectiveness of industrial relations procedures in handling new technology issues.

## Measuring transient intermodulation

continued from page 47  
limiting filter.

The authors are interested in measuring t.i.m. principally to test the effectiveness of anti-t.i.m. measures such as input filters, and to design low-t.i.m. monolithic amplifiers. The availability of a simple and accurate measuring system has already provided useful results, exemplified by the R.I.A.A. preamplifier shown in Fig. 12; a circuit designed around the TDA3210 stereo preamplifier i.c. The filter on the output is intended to minimize t.i.m. in the next stage. This circuit, in terms of traditional parameters, represents the current state-of-the-art in i.c. R.I.A.A. preamps in which the total harmonic distortion is 0.02% at 20kHz. The frequency response is 20Hz to 20kHz  $\pm 0.5$ dB and the dynamic range 100dB.

#### Further reading

- T. Roddam – Calculating transient response, *Wireless World*, Aug. 52, pp. 292-295.
- M. Ojala – Transient distortion in transistorized audio power amplifiers *IEEE Trans. Audio and Electroacoustics*, Sept. 70, pp. 234-239.
- J. R. Stuart – An approach to audio amplifier design, *Wireless World*, August 73, pp. 387-391 – Sept. 73, pp. 439-446 – Oct. 73, pp. 491-494.
- M. K. Vander Kooj – Predicting and avoiding slew-rate limiting, *Electronic Engineering*, Febr. 73, pp. 18-19.
- W. M. Leach – Transient i.m. distortion in power amplifiers, *Audio*, Febr. 75, pp. 34-42.
- B. Sundqvist – Transient intermodulation in amplifiers, *Wireless World*, Febr. 77, pp. 37-39.
- M. Ojala – Non-linear distortion in audio amplifiers, *Wireless World*, Jan. 77, pp. 41-43.
- E. Leinonen, M. Ojala and J. Curl – A method for measuring transient intermodulation distortion, *AES Journal*, July 77.
- E. Leinonen and M. Ojala – Correlation audio distortion measurements *AES Journal*, Jan. 78, pp. 12-19.
- W. G. Jung, M. L. Stephens and C. Todd – An overview of SID and TIM *Audio*, June 79, pp. 58-79 – July 79, pp. 38-47 – Aug. 79 pp. 42-59.
- R. Cordell – Comments on "A method for measuring TIM" and "Correlation of audio distortion measurements", *AES Journal*, April 79, pp. 295-300.
- R. Cordell – Another view of TIM, *Audio*, Feb. 80, pp. 38-49 and March 80, pp. 39-42.
- S. Takahashi, S. Tanaka – A method of measuring intermodulation distortion, *AES Convention*, May 79.
- S. Takahashi, S. Tanaka – A new method of measuring TIM: a comparison with the conventional method, *AES Convention*, Nov. 79.
- P. J. Baxandall – Audio power amplifier design, *Wireless World*, Jan. 78, March 78 and May 78.
- Yuri Miloslavskij – Audio preamplifier with no TIM, *Wireless World*, Aug. 79, pp. 58, 59, 60, 86. www.keith-snook.info
- A. Morando, Introduzione Analitica alla distorsione d'Intermodulazione Dinamica, *IAF.1 suppl. a "Suono"* Aprile 77.
- P. Nuti, Misure di Intermodulazione Dinamica, *Suono*, Nov. 77 pp. 115-120.
- R. A. Belcher, An experimental investigation of test-noise signals for the measurement of non-linear distortion of sound signal, BBC report RD1974/2. □