

# Electrostatic headphones

Constructional design with improved acoustic output

by N. Pollock M.E., M.I.E. Aust.

The electrostatic headphone designs previously published in *Wireless World*, while giving good results, cannot produce high sound pressure levels. They can also be difficult to construct due to the small diaphragm-to-plate clearances required. The headphone and matching driver amplifier presented here attempt to alleviate these problems.

THE SOUND PRESSURE output of a push-pull electrostatic transducer is directly proportional to the differential plate drive voltage, the diaphragm polarizing potential and the reciprocal of the square of the plate spacing. Unfortunately, the polarising potential is dependent on the plate spacing and a high acoustic output can only be obtained by using a high plate drive voltage.

As far as I am aware all commercial electrostatic headphones use wide range step-up transformers to produce the necessary plate voltage when driven by a low voltage power amplifier. Un-

fortunately the design and construction of a suitable transformer is very difficult due to the high inductance, low capacitance and good insulation requirements. Because of these difficulties, most constructional designs are driven directly by high voltage amplifiers. Valve<sup>1,2</sup> and transistor<sup>2,3</sup> amplifiers have been used but in all cases the h.t. supply has been less than 400V. For convenience the amplifier h.t. supply is normally used to provide the diaphragm polarizing potential. With a 400V potential the minimum spacer thickness (plate spacing/2) is about 0.5mm which places stringent requirements on plate flatness and diaphragm tension.

Headphone units with the above specifications are limited to a maximum free field r.m.s. sound pressure (rel. 0.00002 Pa) of about 93dB. For orchestra

music at realistic volume levels a sound pressure capability of around 100dB is necessary and for rock music even higher levels are desirable.

## Amplifier design

Most transistors currently available have a maximum  $V_{CE}$  of less than 400V. However, there are a number of special devices designed for tv horizontal deflection circuits which have peak  $V_{CE}$  values of about 1.5kV and power ratings of 10W or more. The present design is based on the Matsushita 2SD 200 but other types such as the BU206, BU209A, MJ105, PTC 146-RT or SK 3115-RT can be directly substituted.

The circuit in Fig. 1 is a development of an amplifier described in reference 3. Two high voltage class A amplifiers are used, one of which is driven by a unity gain inverting buffer. Operation of the amplifier is quite straightforward but it must be remembered that the LM3900 is a current input device<sup>4</sup> with both inputs clamped near earth. All of the amplifiers are biased from the high and low vol-

Fig. 1. Amplifier for one channel. Note that the bias sources A and B supply both channels.

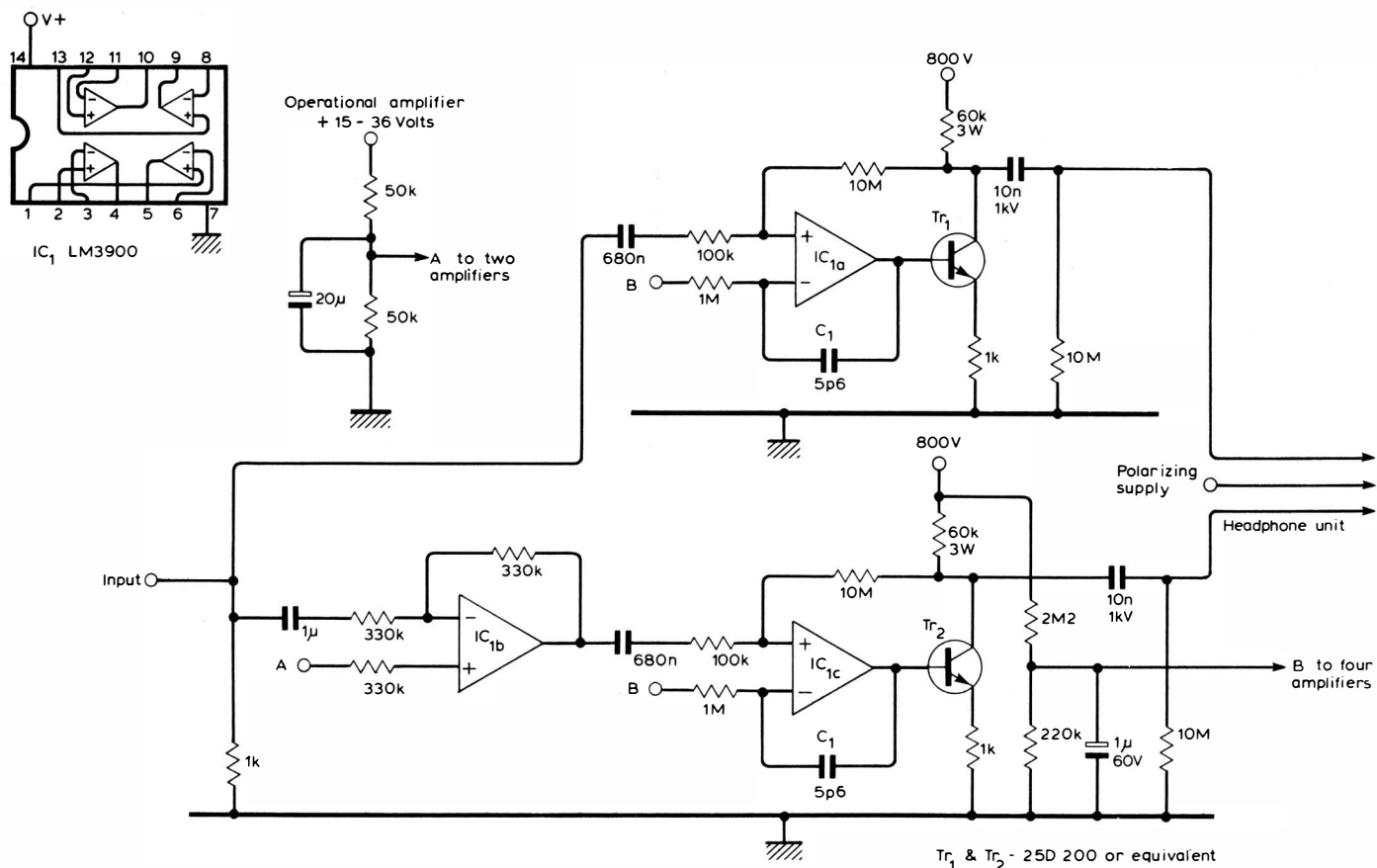

tage supplies so no circuit changes or adjustments are required if the supply voltages are altered. The suggested h.t. of 800V allows the transistors to operate well within their safe operating area. The prototype functioned satisfactorily with a 900V supply, but above this the transistors may suffer from secondary breakdown.

A headphone amplifier sensitivity of 2.8V r.m.s. for maximum output was selected so that it could be driven from the headphone output provided on most amplifiers. A 1kΩ resistor from the input to ground prevents amplifier oscillation when the input is not connected. The prototype was built on two pieces of Veroboard to keep the high and low voltage circuits separate. This arrangement limits the possibility of damage due to construction errors and helps amplifier stability. If instability occurs, the value of C<sub>1</sub> can be slightly increased. The transistors are mounted on small separate heat sinks to avoid the insulation problems of a common heat sink.

The power supply design depends on the transformers available. The prototype used a valve power transformer with a 300V winding to drive a full-wave voltage doubler for the amplifier h.t. supply as shown in Fig. 2. The polarizing supply was produced by a half-wave voltage doubler connected to a potentiometer across the amplifier h.t. supply. Because the headphone diaphragms have a long charging time constant, filtering of the polarizing supply was not considered necessary. A separate

**Fig. 2. Power supplies.** The l.t. supply should be decoupled with 0.1μF disc ceramic capacitors near to each i.c.

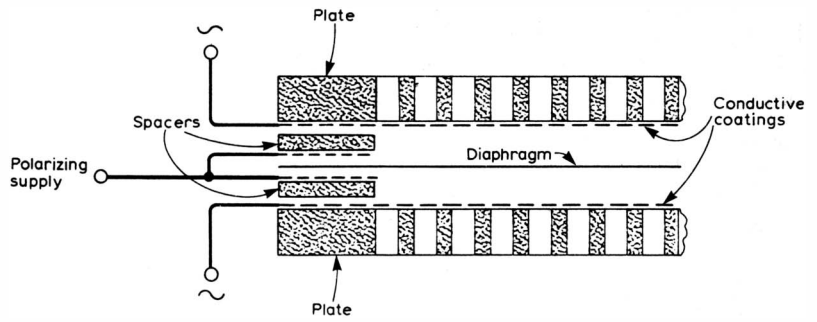
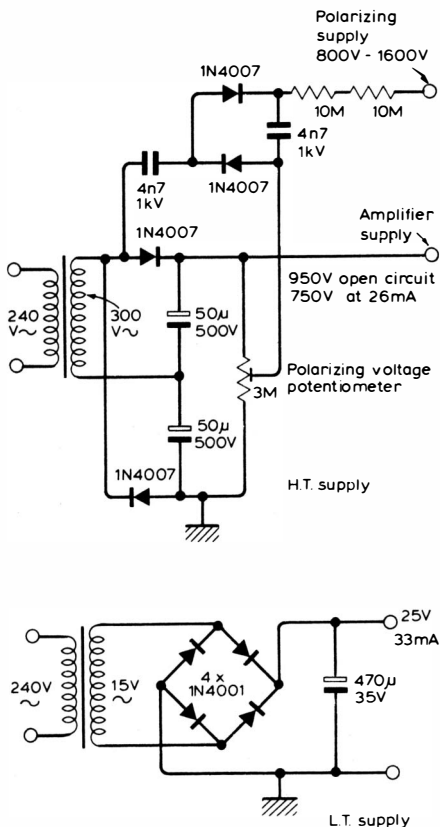
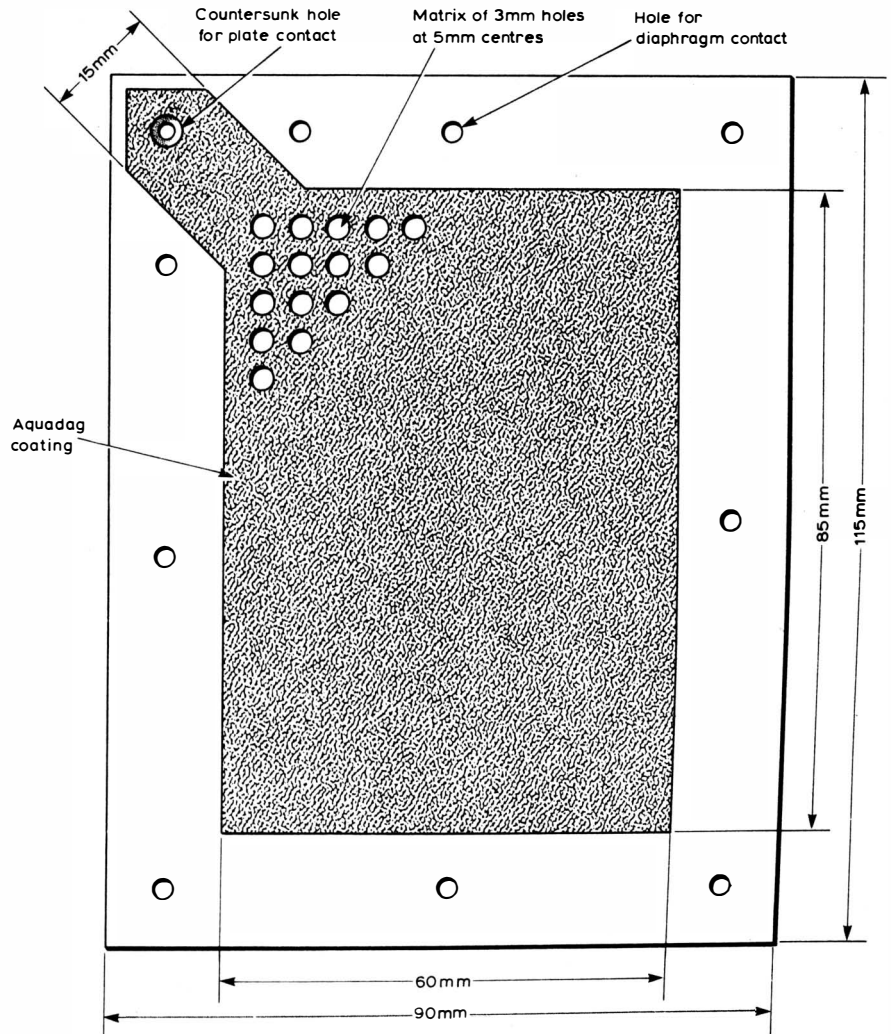
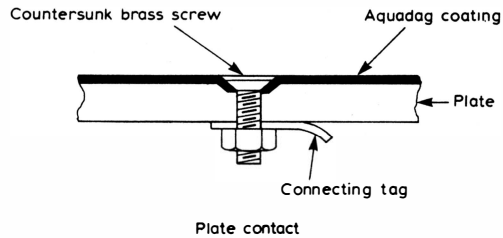

**Fig. 3. Cross-section of a headphone assembly.**

15V transformer was used to provide the amplifier l.t. supply, but if the high voltage transformer also has a 6.3V filament winding, this can be used with voltage doubling.

It is important that the amplifier and power supply are housed in a metal case which is ventilated and connected to mains earth. To avoid ground loops the headphone amplifier signal earth should be derived from the amplifier

**Fig. 4. Fixed plate construction.** Two symmetrical plates are required for each transducer. The matrix of 3mm holes should cover the rectangular conductive area. Aquadag is available from BDH Chemicals, Broom Road, Poole, Dorset. [www.keith-snook.info](http://www.keith-snook.info)



that drives it. Performance details of the amplifier are shown in Table 1.

### Headphone design

The basic requirements for electrostatic headphone transducers, covered in references 1, 2 and 6 and the appendix, are summarized below. The area of the transducer should be large enough to completely cover the ear and give an acceptably low diaphragm resonant frequency without accurate control of the diaphragm tension. The area of the transducer should not be larger than necessary because the interplate capacitance and the problem of drive amplifier design increases with area. For maximum acoustic output the spacer thickness should be as small as possible consistent with unrestricted low-frequency diaphragm movement. The plates must be rigid, at least 20% open and have a perforation spacing

**Table 1.** Amplifier performance. All measurements were made with the headphone transducers connected which provided a plate-to-plate capacitance including leads of about 100pF.

Small signal frequency response	3Hz to 25kHz
Maximum differential push-pull output	1400V pk-to-pk at 5kHz
Differential slew rate limit	25V/ $\mu$ s
Signal-to-noise ratio relative to 1400V	better than 83dB
Maximum distortion before clipping or slew rate limiting	0.1% 20Hz to 20kHz 0.01% below 5kHz

**Fig. 5.** Spacer construction. This "gasket" is 0.8mm thick and can be constructed from any flexible insulating material.

much smaller than the shortest wavelength to be reproduced. The surface resistance of the diaphragm must be sufficiently high to prevent charge migration at the lowest frequency to be reproduced. Sufficient acoustic damping must be provided to damp the diaphragm resonance and to prevent ringing on transients. The rear of the diaphragm should radiate freely to the air.

### Construction

Following the guidelines mentioned above, the headphone design has been optimized for use with the amplifier in Fig. 1. A cross section of the headphone transducer is shown in Fig. 3.

Cut four plates from a sheet of 3mm acrylic, such as Perspex, to the size shown in Fig. 4. Drill a matrix of 3mm holes in all four plates which should be clamped together so that they can be drilled simultaneously. A piece of Veroboard clamped on top of the plates makes a useful drilling guide. Drill a countersunk hole in one corner of each plate so that the head of a M2.5 or M2 brass screw will lie slightly below the surface. Roughen the surface of the plates and remove the sharp corner of the countersunk hole with fine wet and dry paper. After masking the plate as shown in Fig. 4, paint the surfaces and the countersunk holes with a smooth generous coat of Aquadag. After fitting tags into the countersunk holes with nuts, the resistance between the tag and any point on the plate should be less than 10k $\Omega$ . If the resistance is greater add another coat of Aquadag. To prevent localised breakdown of the airgap in high humidity conditions, the Aquadag is painted with a coat of clear polyurethane varnish. When the varnish is dry, rub the surface lightly with fine wet and dry paper to remove the gloss which tends to stick to the diaphragm.

Cut four spacers, 0.8mm thick, to the size shown in Fig. 5. The spacers can be constructed from any good insulating material, I prefer plastic drafting film laminated to produce the required thickness using rubber contact adhesive. This material is easy to cut and flexible enough to clamp the diaphragm around its entire circumference when the transducer is assembled. After sticking the spacers to the coated faces of the plates, drill suitable countersunk holes for the diaphragm contacts. Place the two pairs of plates and spacers face to face and drill for the assembly screws. To provide connections to the diaphragm, the four spacers are painted with generous Aquadag coatings as shown in Fig. 5. These coatings must extend to the inner edge of the spacer and into the countersunk hole, but must be kept clear of the mounting screw holes. After fitting the diaphragm contact screws check that there is a resistance from the connection tags to all points on the Aquadag contacts.

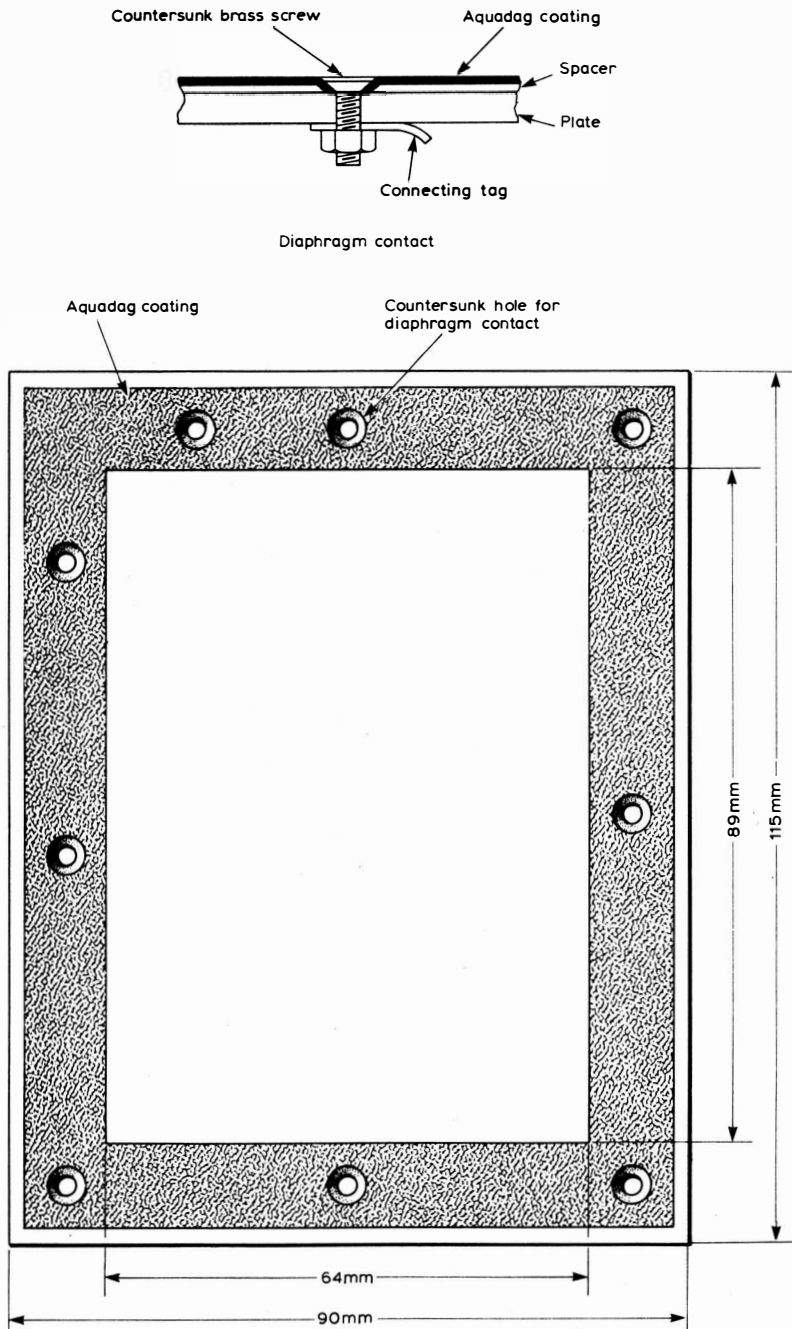

The diaphragm material that I used was a 0.0127mm soft plastic foodstuff wrapping film. From its behaviour it appears to be identical to Vitafilm<sup>1,2</sup>. After extensive experimentation with high resistance coatings I found that the uncoated film, with its very high surface resistance, gave excellent results provided that the diaphragm contacts were arranged as described. This method removed one of the most difficult steps in headphone construction.

To assemble the diaphragm cut a hole somewhat larger than the plates in a rigid sheet of cardboard, stretch a piece of diaphragm material across the hole and attach it to the cardboard with adhesive tape. When the film has been made wrinkle free, place a plate and spacer assembly on each side of the film, hold them firmly together and bolt the complete unit via the pre-drilled holes and diaphragm. Finally, cut the protruding diaphragm film around the outside of the assembly with a razor blade.

To test the headphone units, connect the drive amplifier with the polarizing potential set to its minimum value of 800V and check that the diaphragm remains central. If the diaphragm attaches itself to one plate or oscillates at a low frequency it must be tensioned. This can be done by heating the headphone assembly with a radiator or light bulb until the diaphragm wrinkles at which point it is left to cool.

After testing both units connect the leads to the headphones and insulate all exposed contacts with silicone rubber. The drive units should then be enclosed in acoustic dampers constructed from envelopes of 6mm foam plastic. These envelopes may be sewn around the edges of glued with rubber contact adhesive. The drive unit mounting arrangement will depend on the preference of the constructor. The prototype used an acrylic bridge between two of the assembly screws which protruded through the foam plastic dampers. This bridge was then attached to the headband from an old pair of headphones as shown in Fig. 6. The connecting wires between the headphones and amplifier should be less than 1.5m long and loosely bundled rather than twisted to minimize their capacitance.

With both transducers connected to the amplifier, increase the polarizing potential to just below the value which causes diaphragm collapse or airgap breakdown. For the prototype a maximum potential of 1.3kV was set by the onset of low frequency clicking sounds.

### Safety

Although the high impedance of the polarizing supply ensures that it is not lethal, an uncomfortable shock can be received from the plates at high output. The foam plastic envelopes and the insulation on the connecting leads must be inspected at regular intervals. Provided that these precautions are taken

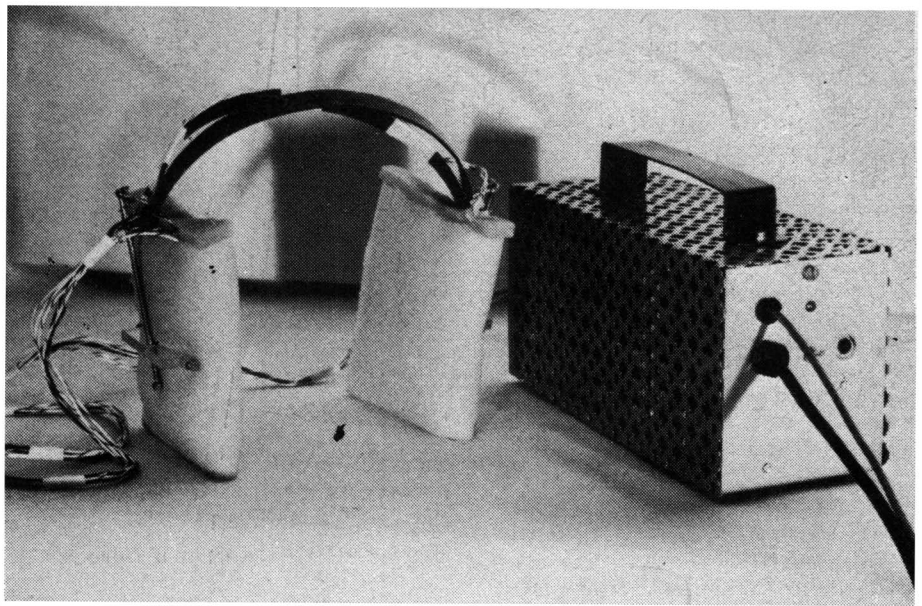

Fig. 6. Author's prototype headphones and power supply.

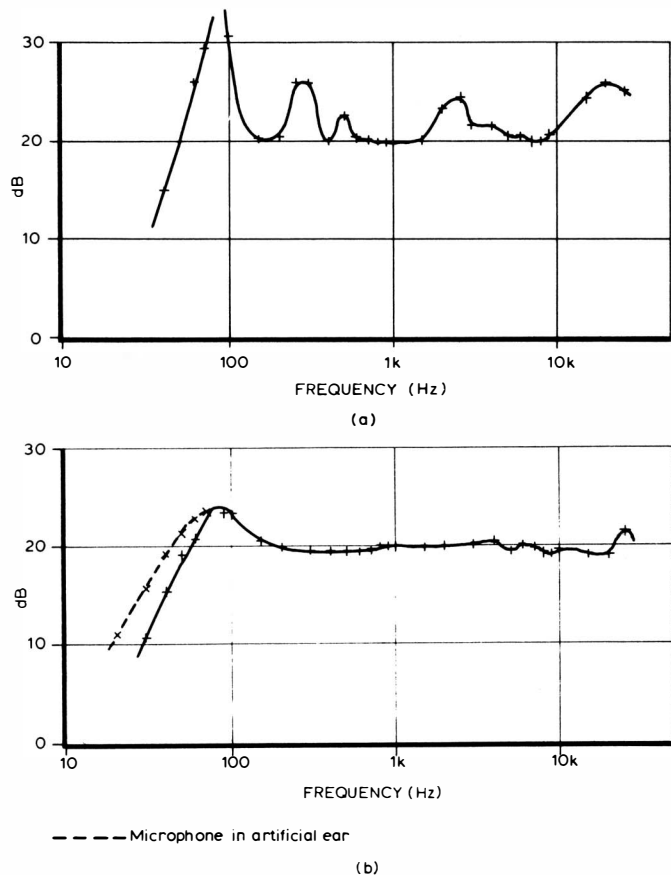

Fig. 7. (a) Headphone frequency response without foam plastic dampers and (b) with dampers.

and common sense is exercised, the headphones are completely safe. However, they are not recommended for use by children.

### Headphone performance

Performance measurements were made with a 12.5mm diameter B & K condenser microphone in contact with the centre of the damper or the centre of the plate when the damper was not fitted. For absolute sound pressure measurements the system was calibrated with a B & K pistonphone.

Without the plastic dampers the headphones had a resonance at about 85Hz, see Fig. 7a, and a pronounced overshoot on the recovery from transients, Fig. 8a. Addition of the dampers produced a frequency response within  $\pm 5$ dB between 40Hz and 30kHz with no overshoot on transients as shown in Figs. 7b and 8b. Placing the microphone in a crude artificial ear, comprising a 6000mm<sup>3</sup> cavity with a 20mm diameter orifice contacting the damper, extended the low frequency  $-5$ dB point down to 20Hz. Brief tests with the microphone

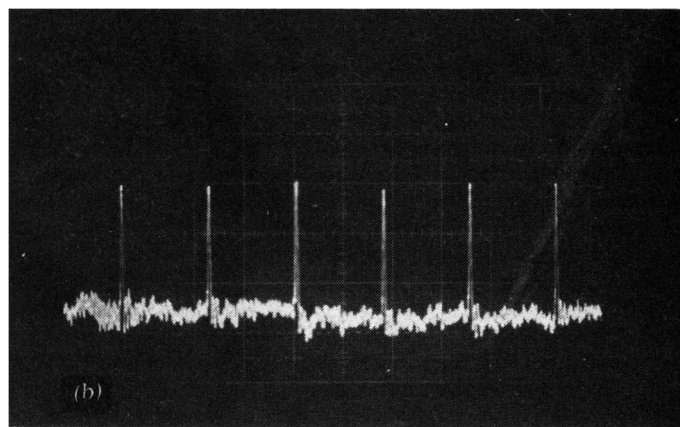
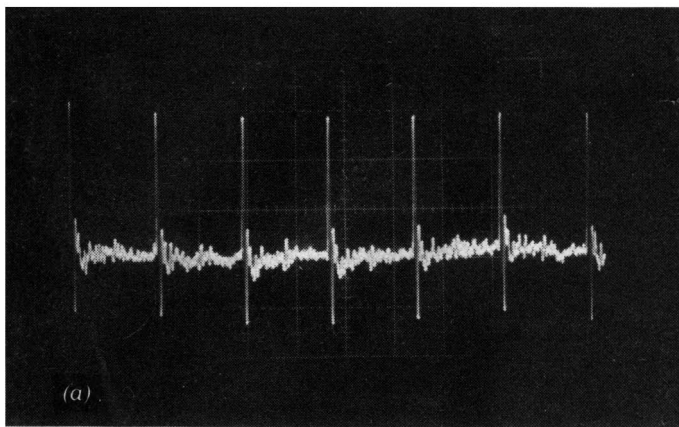

Fig. 8. Headphone response to  $20\mu\text{s}$  pulses at  $1\text{kHz}$  (a) without dampers and (b) with dampers.

moved away from the centre of the headphone unit indicated that the average response over the whole diaphragm area was much flatter than shown in Fig 7b. The r.m.s. sound pressure produced by a  $1400\text{V}$  peak-to-peak differential plate voltage at  $100\text{Hz}$  to  $5\text{kHz}$  was  $102\text{dB}$  (rel.  $0.00002\text{ Pa}$ ).

During extensive tests no difficulties were experienced with the uncoated diaphragms. When the polarizing potential is applied, the charge spreads over the diaphragm and the headphone output rises to its full value within a few seconds. Under extremely dry conditions it is conceivable that the surface resistance may become sufficiently high to prevent charge spreading. If this occurs, gentle breathing on the diaphragm through the dampers should provide a cure. It should be noted, however, that even a fine piece of fluff bridging the diaphragm-to-plate gap will bleed away the diaphragm charge and reduce the headphone output.

Listening tests have been made with a wide range of music. The audible performance is marked by great clarity and I have detected no faults. The acoustic output levels are more than adequate for most listeners but some rock music enthusiasts might prefer another  $10\text{dB}$ . The quality of the recordings and reproduction equipment is very important because all defects are heard much more clearly than with loudspeakers or inferior headphones. This problem with programme source quality was also noted in ref. 1. However, with the best available recordings and good quality equipment, very impressive results are obtained.

## References

1. Wilson, J.P., High quality electrostatic headphones. *Wireless World*, Dec. 1968.
2. Harvey, P.D., Electrostatic headphone design. *Wireless World*, Nov. 1971.
3. Pollock, N., Electrostatic headphone amplifier. *Wireless World*, Circuit Ideas, July 1976. [www.keith-snook.info](http://www.keith-snook.info)
4. Frederiksen, T.M., Howard, W.M. and Sleeth, R.S., The LM 3900 a new current-differencing quad of  $\pm$  input amplifiers. National Semiconductor applications note 72, Sept. 1972.
5. Baxandall, P.J., Audio power amplifier design. *Wireless World*, Jan. 1978.
6. Hunt, F.V., *Electroacoustics*. Harvard University Press, 1954.

## Appendix

### Factors affecting acoustic output

For a push-pull electrostatic transducer with a diaphragm centrally mounted between two plates

$$F = \frac{eQ}{zd} \quad (1)$$

where  $F$  is the force acting on the diaphragm,  $e$  is the differential plate voltage,  $Q$  is the total charge on the diaphragm and  $d$  is the spacer thickness. Also,

$$Q = EC \quad (2)$$

where  $E$  is the polarizing potential,  $C$  is the total diaphragm-to-plate capacitance. And,

$$C \propto \frac{A}{d} \quad (3)$$

where  $A$  is the diaphragm area. By combining the above equations we can show that

$$F \propto \frac{eEA}{d^2} \quad (4)$$

In practice  $E$  and  $d$  are interrelated by airgap breakdown and diaphragm stability. Hunt<sup>6</sup> has shown that for diaphragm stability, the maximum value of  $E$  is limited in the following manner

$$E_{\text{max}} \propto \left( \frac{Td^3}{A} \right) \quad (5)$$

where  $T$  is the diaphragm tension.

From the last two equations the maximum diaphragm force, and hence the maximum acoustic output, is given by

$$F_{\text{max}} \propto e \left( \frac{AT}{d} \right)^{1/2} \quad (6)$$

If the transducer completely covers the ear, the force per unit area is a more relevant parameter and the above expression can be re-written to give

$$\left( \frac{F}{A} \right)_{\text{max}} \propto e \left( \frac{T}{Ad} \right)^{1/2} \quad (7)$$

or

$$\left( \frac{F}{A} \right)_{\text{max}} \propto e \left( \frac{T^2}{A^2 E} \right)^{1/2} \quad (8)$$

The maximum polarizing potential that can be used before the diaphragm-to-plate airgap arcs is given by

$$E_{\text{max}} \propto d \quad (9)$$

therefore

$$\left( \frac{F}{A} \right)_{\text{max}} \propto \frac{e}{d} \quad (10)$$

or

$$\left( \frac{F}{A} \right)_{\text{max}} \propto \frac{e}{E} \quad (11)$$

For the diaphragm tension and dimensions of a typical headphone transducer, diaphragm instability usually occurs before airgap breakdown so equations 7 and 8 should be used. For high frequency transducers using high tension diaphragms, equations 10 and 11 would probably be appropriate.

From equations 7 and 8 the design requirements for a high output transducer are; a high diaphragm tension and small diaphragm area to give the highest acceptable diaphragm resonant frequency. The smallest plate spacing consistent with low frequency diaphragm movement and manufacturing difficulty.

It is important to note that a reduction in output caused by increasing  $d$  cannot be offset simply by increasing  $E$ .

### The author

Neil Pollock studied mechanical engineering at Melbourne University and, after graduating, spent three years working with aircraft flight test instrumentation. Neil then gained a masters degree for work on the design of aerofoil sections for transonic speeds. He also has an interest in electronic and optical instrumentation for wind tunnels. Neil says his main hobby is designing unconventional mechanical and electronic devices which avoid the normal textbook method. He also admits that, although interesting, his approach is not always as good as the standard method.

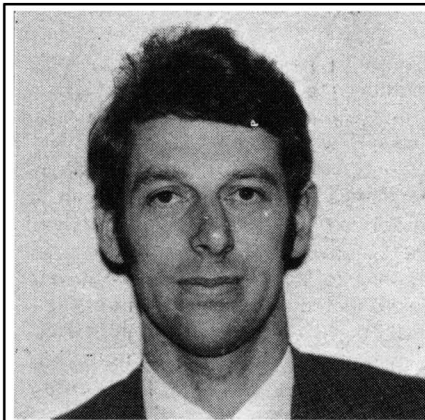

# Electrostatic headphone amplifier

This circuit has been used successfully with a pair of headphones based on the W.W. design Dec. 1968. The amplifier can be driven from the headphone output of most power amplifiers. Potentiometers  $R_5$  and  $R_6$  are used to set  $V_1$  and  $V_2$  at half the supply voltage.

Resistor  $R_1$  is required to compensate for the small signal resistance of a diode in the non-inverting input of  $IC_{1b}$ . If headphones of greater capacitance than 150pF are used it is necessary to reduce  $R_2$  and  $R_3$  to maintain the power bandwidth. It may then be necessary to heat sink the power transistors. The +15V bias supply for  $IC_{1a}$  and  $IC_{1b}$  must be well filtered. The amplifier has a

small signal frequency response of (-3dB) 10Hz to 40kHz, a power bandwidth of 10Hz to 15kHz, and a total harmonic distortion at 1kHz (almost entirely second harmonic) of 0.1% at 50V pk-pk and 1.0% at 300V pk-pk output.

N. Pollock,  
Sandringham,  
Australia.

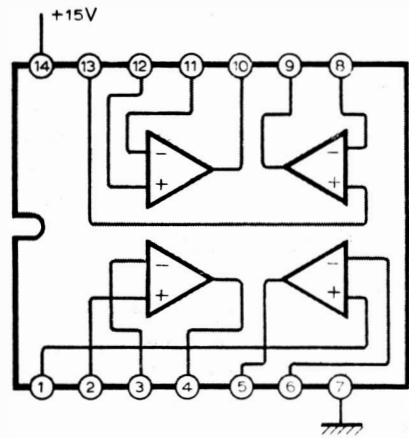
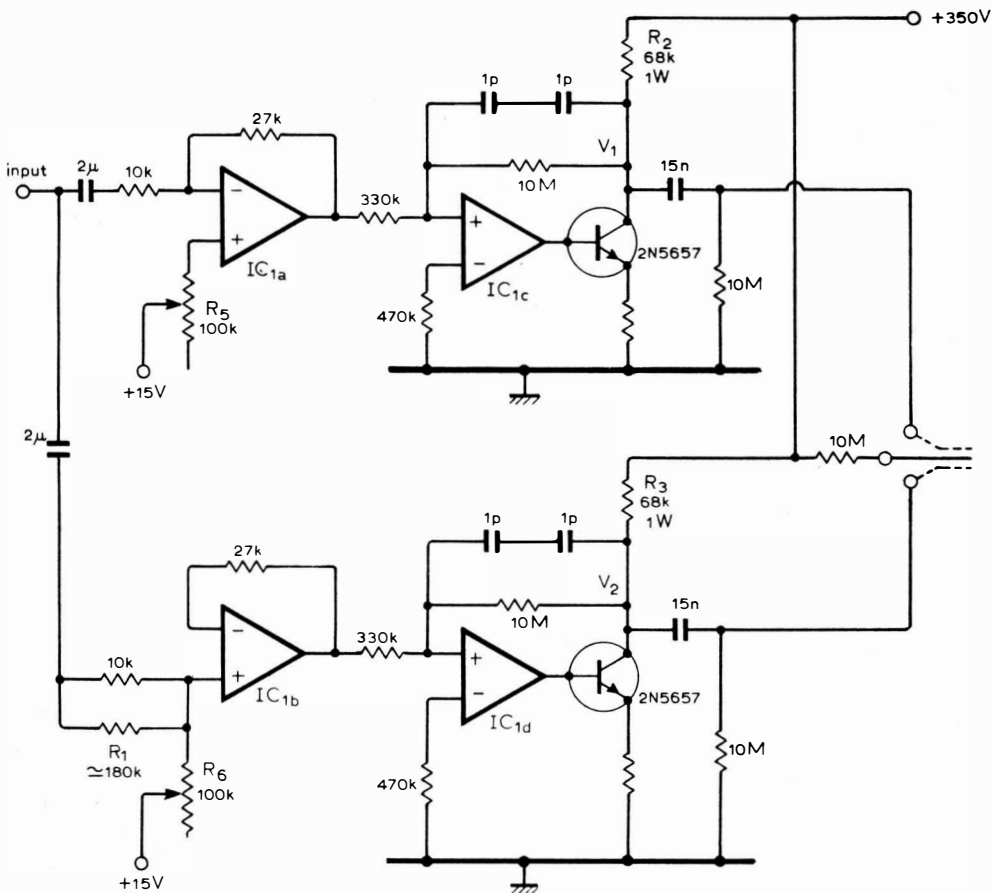

IC<sub>1</sub> LM3900N

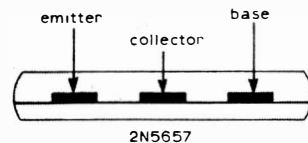

# Short-circuit protector

The short-circuit protector shown is fast and cheap. The transistor is biased to saturation and the collector-emitter voltage is therefore less than a volt. If a short-circuit occurs, the collector is pulled along the constant current line of its output characteristic corresponding to the base bias current  $I_B$ . The short-circuit current is therefore restricted to some value say  $I_{max}$ . Suppose that a maximum load current of  $I_{max}$  is to be made available from a supply of  $V_s$ , and the transistor has a current gain of  $h_{FE}$ , then the base resistor is calculated as follows. As  $I_B = I_{max}/h_{FE}$ , and because  $V_{BF}$  is small,  $R_B \approx V_s/I_B$ . Therefore  $R_B \approx V_s h_{FE}/I_{max}$ . If the precise current gain of the transistor is not known, or if a variable  $I_{max}$  is necessary,  $R_B$  may

be made partly variable and adjusted on test. For a +15V supply from which at least 100mA may be drawn, suitable components for the short circuit protector would be a silicon p-n-p transistor with  $h_{FE}$  100 (e.g. BC327) and a base resistor of 12kΩ. The output voltage will then be 14.5V and the value which  $I_{max}$  reaches will exceed 100mA.

Under normal operation very little power is dissipated in the protection transistor. Under a short-circuited load condition the power developed is  $V_s I_{max}$  watts. For negative supplies a n-p-n transistor may be used in the same configuration.

M. C. Hatley,  
Robert Gordon's Institute of  
Technology,  
Aberdeen.

