

Thyristor control of shunt-wound d.c. motors

by F. Butler, B.Sc., M.I.E.E., M.I.E.R.E., O.B.E.

Practical design details are given for a controller which provides over 2kW output from 230V single-phase mains. It is conservatively rated and will smoothly vary the speed of any motor, up to 2hp, from standstill to 90% of the rated full speed. It incorporates simple protective devices and, by omitting a few components, required only for motor control, it can be used as a high-power lamp dimmer or heat regulator.

Many readers will be familiar with the principles of thyristor-controlled lamp dimmers or speed regulators for conventional power tools which incorporate a.c.-d.c. series-wound motors. A characteristic of the series motor is that, as the load on it is increased, the machine slows down, whereas it will tend to race on no-load. For some purposes these are acceptable or even desirable properties but in other applications we require a motor which can be set to any desired speed and maintain this speed in spite of load changes. A shunt-wound d.c. machine comes close to meeting these requirements though there is some inevitable drop in speed as the load increases, the fall being most noticeable in small machines with high-resistance armatures. The speed may be controlled by adjustment of the field current or by variation of the armature voltage. Weakening the field serves to increase the speed; reducing the armature voltage, with a fixed field, reduces the speed. For a given motor, torque is proportional to armature current while the horsepower is proportional to the product of torque and speed. Speed reduction necessarily results in reduced power for a fixed maximum armature current.

Electronic speed control

One method of electronic speed regulation calls for constant shunt field excitation while the motor armature is supplied with a train of current pulses of variable shape or duration and hence of variable mean and r.m.s. value.

Two methods of supplying fixed power to one resistive load and controlled variable power to another are shown in Fig. 1. With minor modifications these methods are directly applicable to motor speed control. The diode rectifier bridge supplies fixed mean power to R_1 which might represent the shunt field winding of a motor. Adjustable mean power in R_2 is obtained by varying the timing of the

thyristor trigger pulses. Although both circuits give identical waveforms, that using the single thyristor has some advantages and, in what follows, will be used in preference to the other.

When a motor armature is substituted for R_2 , a number of problems are encountered. First, the rotating armature generates a back-e.m.f. and it will only pass current if the thyristor is triggered on and if, at the same time, the instantaneous forward voltage from the rectifier bridge exceeds the motor back-e.m.f. Next, the armature is inductive and a free-wheel diode must be connected across it to allow circulating current to continue even when the thyristor is blocked. The thyristor gate trigger signal is normally a short-duration pulse with an amplitude of 3 volts or so from a 20-Ohm source. A longer pulse would simplify matters but would require much more mean power from the generator and would cause excessive gate-circuit energy-dissipation.

When used for speed regulation the circuits of Fig. 1 give a poor performance, manifested by gross instability of motor speed, with dangerously high transient currents in the system. On starting from rest, the motor back-e.m.f. is zero and, even with retarded trigger pulses, a relatively large armature current is drawn. The motor speed quickly rises, with the result that the next few trigger pulses fail to turn on the thyristor because, at the firing instant, the motor back-e.m.f. exceeds the output voltage from the rectifier bridge. The speed therefore drops and in due course the thyristor fires again with another current pulse of damaging amplitude. The resulting hunting, overshoot and undershoot or stop-go working is such as to rule out this simple scheme. What is needed is some means of triggering the thyristor, with any desired gate-pulse delay, independently of the motor back-e.m.f. A simple modification which allows this to be done is shown in Fig. 3. The main rectifier-bridge diodes

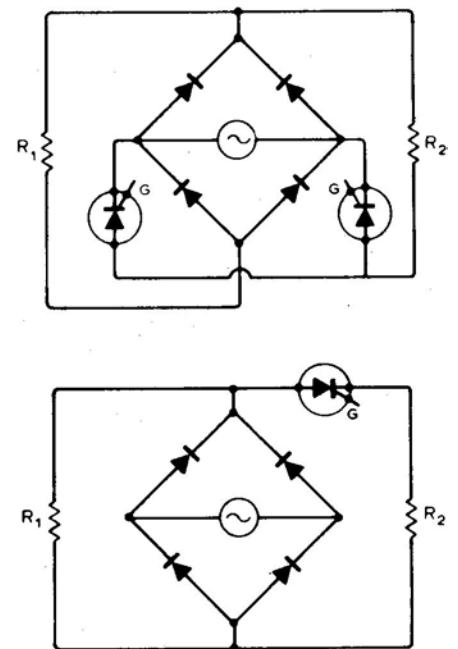

Fig. 1. Diode-thyristor bridges to produce fixed power in R_1 and variable power in R_2 .

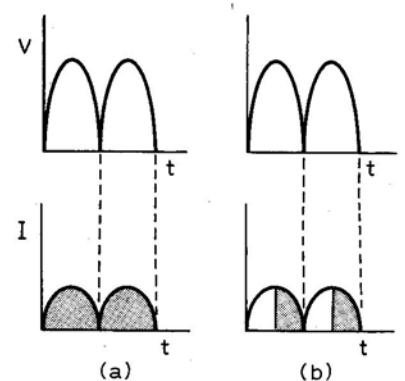

Fig. 2. (a) shows current and voltage in R_1 , while that in R_2 is shown in 2(b).

D supply the motor field directly and feed the armature through the thyristor, while FWD represents the free-wheel diode.

Two auxiliary diodes D_1 are used to feed the thyristor anode through a resistance R . Regardless of the presence of the motor, the mean power in R is controllable by the thyristor trigger pulse delay, exactly as in a lamp dimmer. There are no back-e.m.f. problems associated with the resistive load. The thyristor is fired regularly at times dictated only by the properties of the trigger module. If at any instant, after triggering, the motor back-e.m.f. exceeds the bridge output voltage, the motor simply draws no current; otherwise it takes current proportional to the net voltage round its own circuit loop. This apparently trivial modification at once guarantees complete stability and smoothness of operation at all speeds and loads. In practice the resistance R must at all times draw a current which exceeds the thyristor holding current, typically 100mA. It is convenient to use a low-power mains-voltage lamp, say 40W, the brilliance of which serves as a visual indication of speed, useful if the motor is remote-controlled.

The combination of diodes D and D_1 effectively isolates the motor and resistor from each other, and it will be seen later that the diodes D_1 also provide a convenient source of power for the trigger pulse generator, which itself must be unaffected by the back-e.m.f.

Main power unit

This is virtually a repeat of Fig. 3, with the addition of switches, meters and protective devices. The complete circuit is shown in Fig. 4. On the a.c. side, the line wire includes a switch, a current-limiting fuse, a circuit breaker and a small iron-cored reactor with a shunt capacitor to mains neutral. The circuit breaker is in effect a quick-break switch actuated by a bi-metal strip. The working current is set by the makers at a specified value and the unit will carry this current indefinitely. A 15% overload causes it to trip after about 20

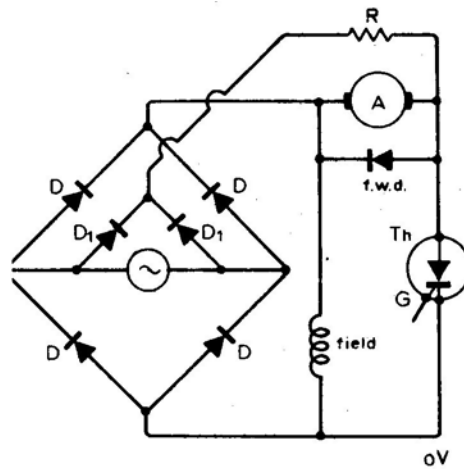

Fig. 3. Basic circuit of power unit showing auxiliary diodes D_1 and resistive load R .

minutes. It will clear a short circuit in 10 milliseconds but will sustain brief overloads, e.g. motor starting currents, up to three times normal, for about 4 seconds without tripping. The RC combination connected across the armature serves two purposes. With small motors, having armatures of high impedance, the values chosen (22 ohms and 6 microfarads) are such as to shunt away from the armature a substantial portion of the a.c. components of the pulsed current. The capacitor is almost ineffective for this purpose with large machines but it tends to reduce sparking, improve commutation, and cut down r.f. interference.

As regards physical construction, the whole assembly is mounted on an aluminium sole-plate 18in x 18in x $\frac{1}{4}$ in, with $\frac{7}{8}$ in ventilation holes drilled below the rectifier bridge. The front panel, 8in x 7in x $\frac{3}{16}$ in, carries the armature current meter (0-20A d.c.), the mains switch, a motor switch and the speed control rheostat.

Two of the four main rectifier diodes and the free-wheel diode share a common heat sink, 6in x $3\frac{1}{2}$ in x $\frac{1}{4}$ in aluminium. The remaining two power diodes are mounted on insulated plates, each $3\frac{1}{2}$ in x $2\frac{3}{4}$ in x $\frac{1}{4}$ in. The two auxiliary diodes do not require

special cooling arrangements. The controller cabinet has louvred sides to promote free air circulation and the power resistors are mounted near the top, clear of other components. Construction follows normal practice, avoiding multiple earths and ground loops, and ensuring that go and return wires lie side by side, well clear of the trigger module.

Trigger circuit module

Various trigger circuits have been tried, including unijunctions, two-transistor equivalents of unijunctions and blocking oscillators. The best has been found to be a simplified version of the Mullard trigger module, type MY 5001. This is available ready made, although it is easily constructed using a few discrete components. The circuit actually used is given in Fig. 5. The unit, which includes only one active device, a silicon p-n-p transistor, type BFX29 or similar, is capable of triggering thyristors of all types, including the very largest. It provides a train of pulses of variable delay with respect to the zero-crossing instants of the a.c. supply. From the full-wave rectified supply, a 20-volt zener diode, fed through a 10R, 10W resistor, produces a fiat-topped trapezoidal waveform, clipped at +20V, which dips sharply to zero at twice the supply frequency. The transistor is connected to a small oscillator transformer, collector winding 300 turns, base winding 100turns, each 36swg wire, wound on an audio-grade ferrite cup core 1 $\frac{3}{8}$ in dia. $\frac{7}{8}$ in long. The transistor base is biased to about +10V mean with respect to the negative line by two 4.7kR resistors connected across the zener diode. At the start of a trigger cycle, the voltage across C (0.25 μ F), is zero. The capacitor begins to charge up exponentially through the 100k rheostat and 1.8kR resistor. As soon as the voltage across C exceeds its base bias, the transistor starts to conduct. Provided that the transformer windings are properly phased, positive feedback starts a self-oscillation. So much current is drawn that the capacitor is rapidly discharged through the transistor, producing a single pulse in the collector winding. This pulse, fed through 22R, triggers the thyristor. Multiple pulses may be produced during some particular half-cycles of the supply frequency but this is of no consequence since the thyristor has already been turned on by the first pulse of the sequence. Pulse-burst trigger signals may indeed be desirable with inductive loads. However, we wish to start timing the next master trigger pulse from the zero-crossing instant of the supply voltage. The circuit provides for this automatically. Whenever the trapezoidal wave across the zener dips to zero, the 50 μ F capacitor, charged to about 10V, retains this charge long enough to drive the transistor base voltage negative with respect to the emitter, causing heavy conduction and very rapid discharge of the timing capacitor.

The small silicon diode across the base winding suppresses pulses of undesired polarity while the damping resistor across the collector coil controls ringing or pulse

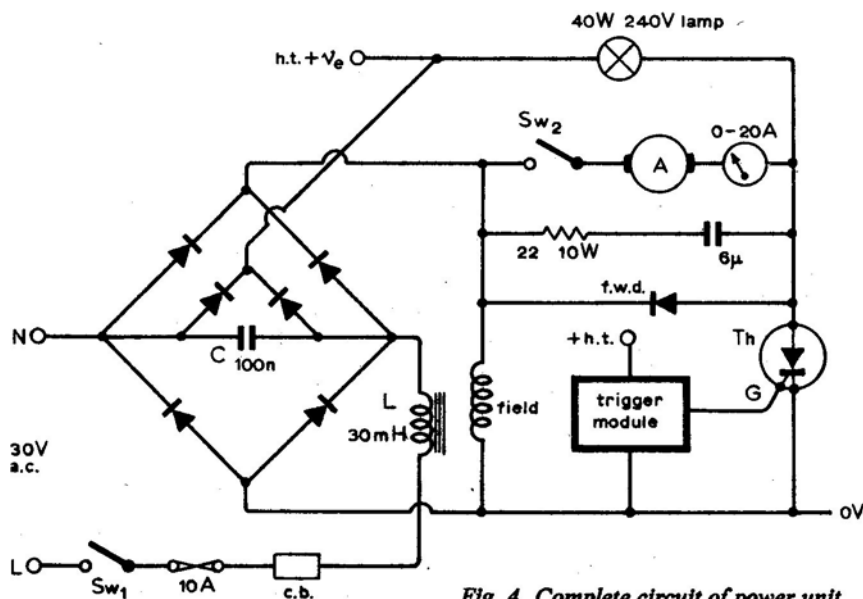

Fig. 4. Complete circuit of power unit.

overshoot. Peak base current is limited by the 1200R resistor.

It is clear that another transistor could be substituted for the 100kR variable timing resistor. This opens up new control possibilities. The extra transistor could simply form a linear (constant-current) charging device or could be used in a feedback system to give current-limiting in the load circuit. With a little more design effort it would be possible to tailor the motor speed-torque characteristic to meet any reasonable requirement. Several such schemes have been tried successfully but most of them require transformers with associated rectifier bridges, RC delay circuits or preset controls. For the task in hand the added complexity is not really justified.

Protective measures

Semiconductor devices, otherwise reliable, are easily destroyed by faults which cannot be cleared fast enough by ordinary fuses or circuit breakers. High-voltage line, transformer or load transients can also cause diode and thyristor breakdown. Special current-limiting fuses are available from several companies but in the case of equipments rated only at a few kilowatts it is worth spending a little more money on the semiconductor devices, choosing those with higher than normal peak voltage and current ratings. Normal fuses or circuit breakers then give adequate protection if the equipment is used sensibly.

One point about thyristors is worth stressing. Even in the absence of gate drive, the sudden application of a high voltage is liable to cause forward breakover into conduction. This is non-destructive if the applied voltage does not exceed the peak forward voltage rating of the device, and if the current is limited by the load to a safe value. To avoid this trouble the rate of rise of voltage ahead of the thyristor can be limited by a suitable RC network or perhaps by a rudimentary LC filter. Unfortunately such measures tend to spoil the voltage regulation or to lower the overall efficiency of the system.

In the present case a small filter reactor of about 30mH followed by a 0.1µF capacitor gives an acceptable compromise. The inductor, consisting of 100 turns of 16swg wire wound on a laminated Stalloy core with a centre-limb cross-section $\frac{7}{8}$ in x $\frac{7}{8}$ in. (no air gap), saturates with less than full load current and in fact drops about 12 volts at all loads above 1A r.m.s.

Construction and testing

The main rectifier bridge, auxiliary diode, free-wheel diode and thyristor assembly was built first and wired up as a self-contained unit. Heavy-gauge well-insulated wire was used, with solder-lug terminations. Substantial bolts with nuts and lock washers were used to ensure permanent, low-resistance connections.

The trigger unit was then built as a separate module and tested on a temporary power supply. The output pulses, though of large amplitude, are so narrow that they are difficult to see on an oscilloscope. A check was made that the unit would actually trigger a thyristor with

a lamp load. Failure to work will almost certainly be due to reversed polarity of one of the pulse-transformer windings.

The controller was then assembled in its final form, fitted with a 3A fuse and checked first with a 100W lamp load and then with a fractional horsepower motor. The fuse was then replaced by one of 10A rating and the controller tested with a 1kW heater load.

Some caution is necessary when running large motors. The mains switch on the controller should turn on the trigger pulse generator and motor field supply. When these have settled down, a second switch with the motor armature can then be closed, the trigger module being set for the maximum possible firing delay angle. The motor can then be started slowly by advancing the speed control knob.

When shutting down the motor, the speed control is backed off to zero, the motor switch opened and the mains switch turned off. Attempts to start a large motor at full speed will instantly blow fuses, open circuit breakers or destroy the semiconductor devices. There is nothing remarkable in this since it would be almost equally disastrous to switch a large d.c. motor directly on line without a starter resistance in series with the armature. It is an interesting thought that a conventional starter, with field regulator, no-volt release, overload trip and stepped starter resistance, but with no provision for speed control, costs more than the parts for an electronic controller which performs both starting and speed control functions. Moreover, the electronic unit calls for little or no maintenance.

Since completion, the controller has been tested for long periods with three different motors. The smallest was a DELCO machine, conservatively rated at 1/6hp but easily capable of delivering 1/4hp. Fitted with sleeve bearings, the machine ran smoothly and quietly at all speeds up to 1,500rpm. The armature was of relatively high resistance and reactance and it was found that the shunt capacitor took an appreciable part of the alternating component of the pulsed armature current. This capacitor also does something to reduce

r.f. interference due to commutation.

The next test was on a Metropolitan-Vickers motor rated at 230V, 1hp, 2,850-rpm. This ran well at all speeds from crawling up to 2,500rpm, with a surprisingly high torque at quite low speeds, although at this end of the range the motor slowed down with an increased load. The last machine to be tried was an aircraft engine-driven generator rated at 100V, 600W. Its field was intended to be energised from a 24V supply and not directly from the brushes. Strictly speaking, to run this as a motor calls for a change in the brush position but this adjustment proved to be impossible because the brush rocker was already at the wrong end of its travel.

The armature impedance was very low and the shunt capacitor thus virtually inoperative. The machine was designed for forced-air cooling and so could only be tested for short periods at anything like full load. Nevertheless it was operated between 0V and 200V (twice the rated maximum), at speeds between 0 and 8,500-rpm. At top speed, friction and windage losses were such that the motor, running light, drew about 200W from the supply.

In every case, commutation was sparkless at all speeds and loads although sudden load changes provoked mild, harmless sparking until the machines settled down to the new conditions.

With the controller fitted in a grounded metal case and with screened cables to the motor there is surprisingly little radio interference on medium or long waves and nothing is audible on the v.h.f. and television bands. With the controller wiring exposed, no earth on the motor frame and with un-screened cables, interference is of course easily detectable. Listening to this on a transistor receiver allows one to check the regularity of firing of the trigger pulse generator. An erratic note calls for a methodical check of the entire system.

Conclusion

A good deal of work has gone into the development of this controller. The use of auxiliary diodes to feed current to the thyristor anode through a resistance load (in practice a lamp), eliminated an intract-

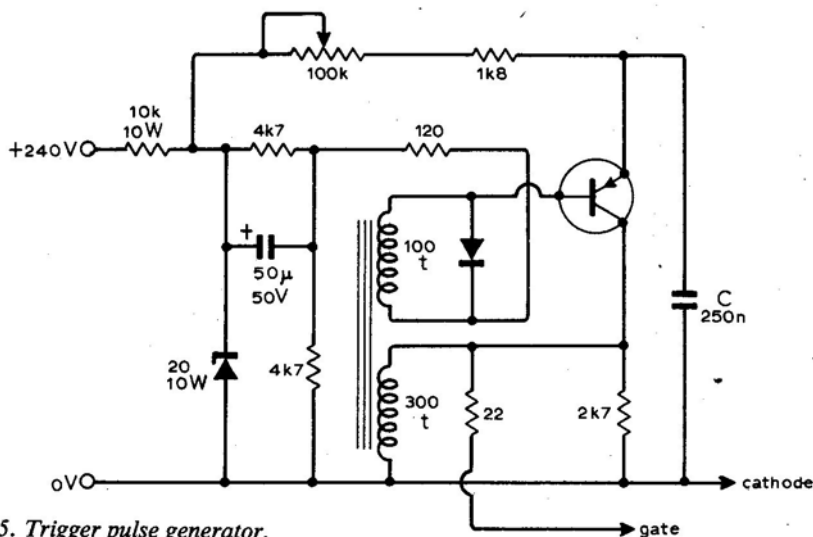

Fig. 5. Trigger pulse generator.

able hunting phenomenon which took the form of wild fluctuations of armature current and motor speed. The supplementary diodes are in any case required to supply the pulse generator with a full-wave rectified sinusoidal voltage, uncontaminated by the variable d.c. back-e.m.f. of the motor. This latter, if present, results once more in erratic firing, unsynchronized with the supply frequency.

Merely by up-rating the semiconductor devices the scheme appears to be applicable to large motors, certainly up to tens of horsepower, operating from single-phase mains, and without limit from polyphase lines, though of course the trigger module becomes more complicated.

Without modification, the controller also works satisfactorily with resistive loads (lamps or heaters), up to 2kW, or, by changing fuses and circuit breakers, up to 7kW at low ambient temperatures. Larger heat sinks are required at loads much above 3kW. If resistive loads only are to be used, the free-wheel diode, shunt capacitor and resistance and the built-in lamp load can be removed as well as the two auxiliary diodes. We are of course then left with a simple, well-known circuit which has no novel features.

There are known methods of compensating for the voltage drop across the motor due to its armature resistance. This is responsible for the drop in speed which is observed when the load is increased. One simple scheme uses feedback, from a low-value resistor in series with the armature, to advance the firing angle of the thyristor in proportion to the load. The idea must be used with caution since it can easily lead to gross overloading of the controller and the motor. Complete safety requires the addition of an overriding control which will limit the circuit current to a safe value. It must come into action only when this limit is reached, otherwise it tends to counter the effect of the first control.

A word of caution must be given about

Parts list

Resistors ($\frac{1}{2}$ W except where specified)

- 1 10kR,10W
- 1 22R,10W
- 1 22R
- 1 120R
- 1 1.8kR
- 1 2.7kR
- 2 4.7kR
- 1 100kR wirewound potentiometer

Capacitors

- 1 6 μ F 1000V working
- 1 0.1 μ F 1000V
- 1 0.25 μ F 350V
- 1 50 μ F50V (tantalum)

Semiconductors

- 5 Silicon power diodes 35A 600PIV
- 2 Silicon power diodes 5A 600V
- 1 Thyristor 30A 600V
- 1 Small signal silicon diode
- 1 Silicon p-n-p transistor (Mullard BFX29 or similar)
- Zener diode 20V10W

Miscellaneous

- 2 10A single pole switches
- 1 10A fuse and fuseholder
- 1 10A circuit breaker (BCE.Type K, Catalogue Number A/490)
- Ammeter 2 $\frac{1}{2}$ in, 1-20A d.c.
- 40W 240V lamp with batten holder
- Ferrite cup core (audio grade 1 $\frac{3}{8}$ in x $\frac{7}{8}$ in)
- Lamination stack (Stalloy or similar), 2 $\frac{3}{4}$ in x 2 in x $\frac{7}{8}$ in

the techniques of current and voltage measurements on equipments of this type. Moving coil d.c. meters and rectifier-type a.c. instruments read the arithmetic mean values of current and voltage. In the a.c. case the meter readings are calibrated in terms of the r.m.s. equivalent for a sinusoidal source. Their readings with pulsed sources must be treated with caution. Thermocouple, dynamometer or moving-iron instruments measure true r.m.s. values but in the last two cases, the calibration normally holds good only at low frequencies. High harmonics can cause errors of reading. When measurements of input

power, output power and efficiency are being made, there is really no substitute for a wattmeter.

Acknowledgment

Although many British and foreign companies offer a wide range of thyristor-controlled motor drives (the record for size is probably held by the Americans with a 12,000hp reversible rolling mill motor), it is still difficult to find much practical information in the literature about small installations. In developing the present unit valuable background material has been gathered from the (American) General Electric Company publication "Silicon Controlled Rectifier Manual".

The Mullard Technical Handbook series also contains a wealth of useful information, particularly Book I, Part 5, "Thyristors and Thyristor-Stacks".

Finally, reference must be made to articles by J. Merrett in *Mullard Technical Communications*, Vol 8, No.80, March 1966 on "Thyristor Speed Control of DC Shunt Motors from a Single-Phase Supply", and "Instructions for Selecting a DC Motor for Thyristor Speed Control". These two papers serve to highlight the subtlety and complexity of the problems in developing this control technique.

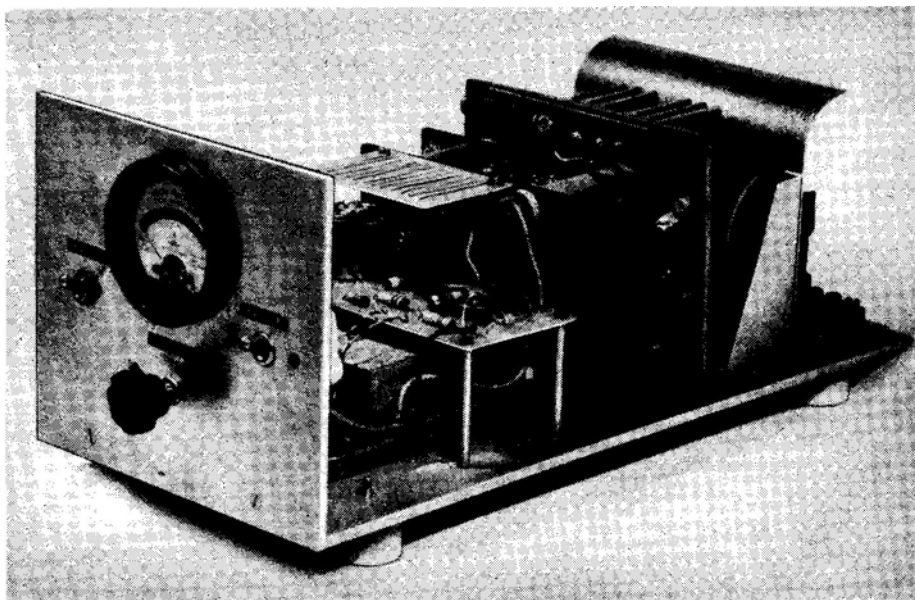

Fig. 6. The completed controller.