

Audio Power Amplifier

by P. L. Taylor*, M.A.

In this article the author puts forward a proposal for a transistor power output stage which does not claim the best possible performance but provides an economic configuration to achieve acceptable results. A circuit diagram for a 30W main amplifier with 0.1% distortion and a hum level of -50dBW is presented together with a description of the design philosophy.

The current-voltage relationship of a semiconductor junction is basically an exponential form. This curve has the property that moving it horizontally along the voltage axis is equivalent to a simple change of the scale of the vertical or current axis. There is an unfortunate consequence when it comes to trying to adjust two exponential curves back-to-back to make a class B output stage, Fig. 1. No matter how one juggles the two curves relative to each other the resultant, shown dotted, always has the same shape; it merely changes in scale. It is a hyperbolic sine and is far from linear. Semiconductor junctions are evidently bad starting material for a class B design.

Matters are somewhat better if a fixed resistance R is included in series with each junction. A few moments' work with pencil and paper shows that, for the nearest approach to a linear resultant characteristic, the resistance should have a value equal to the slope resistance of the junction at the standing or quiescent current. What happens when it does not have this value has been graphically illustrated by Gibbs¹.

There is an important practical consequence. If I_0 is the standing current and V_0 the corresponding voltage drop across the base-emitter junction, then the general equation relating current I and voltage V is,

$$I = I_0 \exp\{K(V - V_0)\}.$$

The slope resistance is dV/dI , and when $I = I_0$, takes on the value $1/KI_0$. If the series resistance has this value we get the particularly simple result that the standing voltage drop across it must be $I_0 \times 1/KI_0 = 1/K$. So if I_0 is firstly chosen, the value of resistance follows and the circuit must be designed to maintain $1/K$ volts across the resistance under quiescent conditions.

Now $K = q/kT_j$ where q is the charge on an electron, k is Boltzmann's constant and T_j is junction temperature. It is the same for all transistors n-p-n or p-n-p, germanium or silicon, and has the value $40V^{-1}$ at room temperature. Hence there is a universal rule

which defines that, for class B operation of any transistor, the standing voltage drop across each series resistor should be 25mV at room temperature†. Here lies the practical difficulty. The 25mV is in series with the much larger, and variable, 550mV, or so, voltage drop V_0 across the junction. It is small wonder that temperature compensating diodes and preset adjustments are required in class B designs. Added to this are the difficulties that the adjustment is critical², K is temperature-dependent (so that strictly the series resistance should

† By a similar argument one obtains another universal rule which defines the transfer conductance of all transistors to be 40mA/V per mA of emitter current at room temperature. It is strange that not many textbooks mention this valuable and easily-remembered fact.

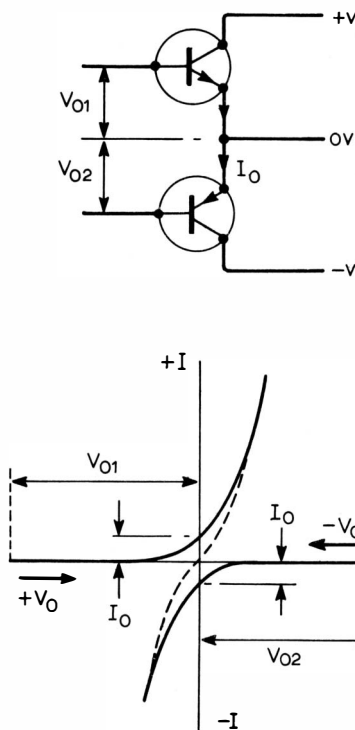

vary with junction temperature) and the series resistance must include the internal emitter resistance of the transistor—about $\frac{1}{2}\Omega$ for type BD121. Therefore, only part of the 25mV is available outside the transistor for monitoring the standing current. All in all, it is surprising how well class B stages have been made to perform.

Class AB is a little better. Typical values are $R = 1\Omega$ and $I_0 = 100mA$, so that the standing voltage drop is 100mV. This voltage is still rather small compared with 550mV but unfortunately it cannot be increased much above this figure because, as I_0 is increased, there are problems of power dissipation in the transistors. On the other hand R is in series with the load so that if this resistance is increased, the peak voltage drop across it reduces the peak power available in the load. That is, R ideally should be small compared with the resistance of the load.

The new circuit to be described attempts to overcome these difficulties by putting the current monitoring resistor outside the main feedback loop.

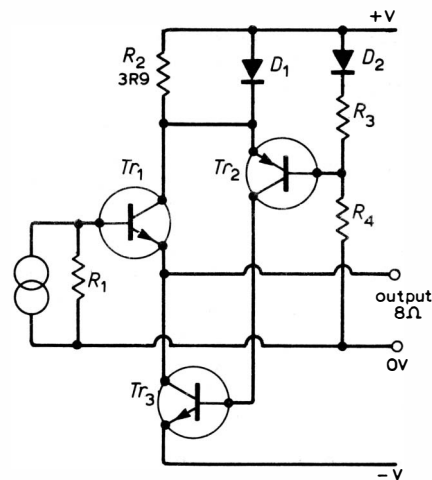

Fig. 2. Basic configuration of power output stage.

Fig. 1 (left). Class B cross-over characteristics constructed from two curves of exponential form.

*University of Salford.

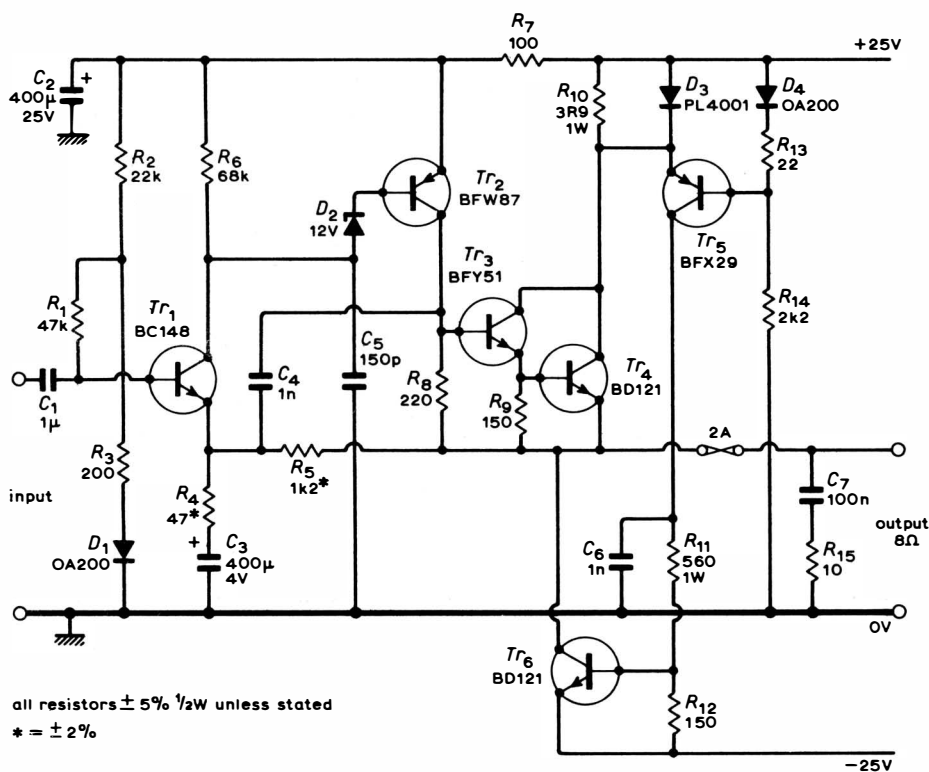

Fig. 3. Diagram of a 30W main amplifier utilizing the described technique.

Circuit operation

The basic circuit³, shown in Fig. 2 has one of the output transistors, Tr_1 , acting as a straightforward emitter follower. The current generator and the resistance R_1 represent a transistor driving Tr_1 and R_2 is a collector current monitoring resistance. In the absence of signal the standing current through Tr_1 is chosen to be 100mA so the voltage drop across R_2 is 390mV. The polarity and magnitude of this voltage is arranged to make diode D_1 partially conduct, but not sufficiently to pass appreciable current.

Ignoring D_1 for the moment, there is seen to be negative feedback round the loop Tr_2 - Tr_3 - Tr_1 . The standing current through Tr_1 and Tr_3 (the second output transistor) is fixed in terms of the voltage drop across R_2 , which is applied to the emitter of Tr_2 , and the fixed voltage applied to the base of this transistor from the chain D_2 - R_3 - R_4 . The diode D_2 is included to compensate for variations in the base-emitter voltage of Tr_2 and the voltage across R_3 is therefore approximately equal to the desired standing voltage drop across R_2 .

Now suppose Tr_1 is driven by a signal. Over positive half-cycles Tr_1 passes more current from the positive supply to the load. The voltage drop across R_2 rises, reducing the collector-emitter current in Tr_2 and hence Tr_3 . This does not matter if the conditions are correct because Tr_1 , provided it has sufficient drive, should be capable of supplying all the current required by the load. What is important, however, is that R_2 has a value which is comparable with an 8Ω loudspeaker load and, if measures were not taken to counteract the voltage drop, the peak output current would severely reduce the voltage at the collector of Tr_1 and would consequently restrict the positive excursions

of output voltage available across the load. In this circuit the voltage drop across R_2 is limited to about 600mV, when D_1 fully conducts. Obviously D_1 must be a small power type to carry the peak current.

Over negative half cycles Tr_1 passes less current which reduces the voltage drop across R_2 so that Tr_2 passes more current and Tr_3 conducts more to supply the required load current from the negative supply. Current through Tr_1 , which is maintained by the negative feedback, still flows through the load. Thus Tr_3 supplies the load current on negative half-cycles but Tr_1 remains in conduction operating as an emitter follower to control the output voltage at all times.

Thus the circuit permits the use of a much higher current monitoring resistance than in a typical class AB amplifier, the resulting voltage drop under quiescent conditions being high enough to permit pre-set adjustments to be dispensed with, but because this resistance is outside the main amplifier feedback loop the peak voltage can be limited by a shunt diode.

Distortion

The distortion produced by this circuit is basically even-order and may be estimated as follows. In practice Tr_1 is a Darlington pair with a current gain of about 2500. On positive half-cycles, when Tr_3 is inoperative, an 8Ω load is therefore presented as a resistance of about $8 \times 2500 = 20k\Omega$ across R_1 . On negative half-cycles the extra gain round the Tr_2 - Tr_3 loop makes the reflected resistance much higher. Therefore, assigning a value of 10kΩ to R_1 creates the condition where on negative half-cycles the current generator works into approximately 10kΩ and on positive half-cycles it works into 10kΩ in parallel with 20kΩ, which is

6.7kΩ. The magnitudes of positive and negative half-cycle output voltage therefore differ by 33% and second-harmonic distortion is approximately half this value or 17%. A loop gain of 170 round the main amplifier loop would reduce this to the target figure of 0.1%.

A practical audio amplifier incorporating the new output stage is shown in Fig. 3. It provides 30W into an 8Ω load and performance is as expected. Distortion is 0.1% at maximum output and is mainly second harmonic. Full output is available up to 15kHz with an input voltage of 600mV r.m.s. With conventional power supplies the hum is less than 10μW with a load of 8Ω.

The following points may be of interest. A minor extravagance seems to be the use of a zener diode D_2 to couple Tr_1 to Tr_2 . This has the effect of defining accurately the voltage drop across R_6 and hence the current flowing through Tr_1 and R_5 . In turn, this defines the voltage drop across R_5 which reduces variations in the output d.c. voltage to less than 100mV—without any pre-set adjustment. If the loudspeaker has a d.c. resistance of 8Ω, an output coupling capacitor can be eliminated. It appears that the use of D_2 is not such an extravagance after all.

An additional point is that Tr_2 does not need a collector load resistance connected to the negative supply. This eliminates not only a potential source of hum, but also the usual "bootstrapping" capacitor. This means that this type of output stage is ideally suited for applications requiring an output down to d.c., such as control and servo drive systems.

References

1. Gibbs, D. S. Letter to the Editor, *Wireless World*, August 1970, pp. 387-8.
2. Blomley, P. "A new approach to class B amplifier design", *Wireless World*, Feb. 1971, pp. 57-61; March 1971, pp. 127-131.
3. Patent applied for.

Sixty Years Ago

The problems of obtaining what is now the basic function of a transmitter—the production of a continuous wave—were, sixty years ago, so formidable that many people were of the opinion that they just were not worth the trouble. In his evidence to the Postmaster-General's Advisory Committee, G. Marconi said "... there has never been submitted here or elsewhere one scintilla of evidence to prove that the continuous or undamped waves have any advantage over intermittent or feebly-damped waves for long-distance working in radiotelegraphy." In an article on methods of obtaining these waves using rotary machines, Hubert Dodell mentioned the difficulty of maintaining a constant frequency, the speed of the machine being affected by the loading due to Morse modulation. "So serious is this difficulty, that the full load is kept permanently on the machine, and the dots and dashes are produced by varying the aerial wavelength so that at times it is in tune with the receiver, and at others it is so much out of tune that the receiver is not affected."