

Simple Class A Amplifier

A 10-W design giving subjectively better results than class B transistor amplifiers

by J. L. Linsley Hood, M.I.E.E.

During the past few years a number of excellent designs have been published for domestic audio amplifiers. However, some of these designs are now rendered obsolescent by changes in the availability of components, and others are intended to provide levels of power output which are in excess of the requirements of a normal living room. Also, most designs have tended to be rather complex.

In the circumstances it seemed worth while to consider just how simple a design could be made which would give adequate output power together with a standard of performance which was beyond reproach, and this study has resulted in the present design.

Output power and distortion

In view of the enormous popularity of the Mullard "5-10" valve amplifier, it appeared that a 10-watt output would be adequate for normal use; indeed when two such amplifiers are used as a stereo pair, the total sound output at full power can be quite astonishing using reasonably sensitive speakers.

The original harmonic distortion standards for audio amplifiers were laid down by D. T. N. Williamson in a series of articles published in *Wireless World* in 1947 and 1949; and the standard, proposed by him, for less than 0.1% total harmonic distortion at full rated power output, has been generally accepted as the target figure for high-quality audio power amplifiers. Since the main problem in the design of valve audio amplifiers lies in the difficulty in obtaining adequate performance from the output transformer, and since modern transistor circuit techniques allow the design of power amplifiers without output transformers, it seemed feasible to aim at a somewhat higher standard, 0.05% total harmonic distortion at full output power over the range 30Hz–20kHz. This also implies that the output power will be constant over this frequency range.

Circuit design

The first amplifier circuit of which the author is aware, in which a transformerless transistor design was used to give a standard of performance approaching that of the "Williamson" amplifier, was that published in *Wireless World* in 1961 by Tobey and Dinsdale. This employed a class B output stage, with series connected transistors in quasi-complementary symmetry. Subsequent high-quality transistor power amplifiers have largely tended to follow the design principles outlined in this article.

The major advantage of amplifiers of this type is that the normal static power dissipation is very low, and the overall power-conversion efficiency is high. Unfortunately there are also some inherent disadvantages due to the intrinsic

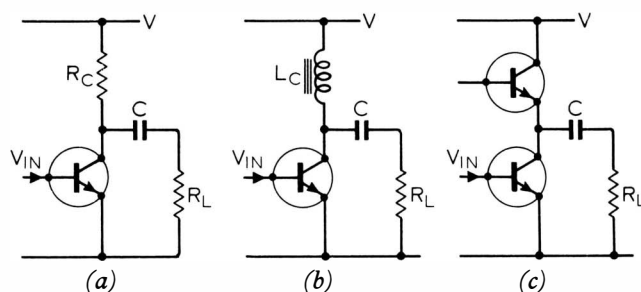

Fig. 1. Basic class A circuits using (a) load resistor R_C giving power conversion efficiency of about 12%, (b) l.f. choke giving better efficiency but being bulky and expensive, and (c) a second transistor as collector load.

dissimilarity in the response of the two halves of the push-pull pair (if complementary transistors are used in unsymmetrical circuit arrangement) together with some cross-over distortion due to the low current non-linearity of the I_c/V_b characteristics. Much has been done, particularly by Bailey¹, to minimize the latter.

An additional characteristic of the class B output stage is that the current demand of the output transistors increases with the output signal, and this may reduce the output voltage and worsen the smoothing of the power supply, unless this is well designed. Also, because of the increase in current with output power, it is possible for a transient overload to drive the output transistors into a condition of thermal runaway, particularly with reactive loads, unless suitable protective circuitry is employed. These requirements have combined to increase the complexity of the circuit arrangement, and a well designed low-distortion class B power amplifier is no longer a simple or inexpensive thing to construct.

An alternative approach to the design of a transistor power amplifier combining good performance with simple construction is to use the output transistors in a class A configuration. This avoids the problems of asymmetry in quasi-complementary circuitry, thermal runaway on transient overload, cross-over distortion and signal-dependent variations in power supply current demand. It is, however, less efficient than a class B circuit, and the output transistors must be mounted on large heat sinks.

The basic class A construction consists of a single transistor with a suitable collector load. The use of a resistor, as in Fig 1(a), would be a practical solution, but the best power-conversion efficiency would only be about 12%. An l.f. choke, as shown in Fig. 1(b), would give much better efficiency, but a properly designed component would be bulky and expensive, and remove many of the advantages of a transformerless design. The use of a second, similar, transistor as a collector load, as

shown in Fig. 1(c), would be more convenient in terms of size and cost, and would allow the load to be driven effectively in push-pull if the inputs to the two transistors were of suitable magnitude and opposite in phase. This requirement can be achieved if the driver transistor is connected as shown in Fig. 2.

This method of connection also meets one of the most important requirements of a low distortion amplifier—that the basic linearity of the amplifier should be good, even in the absence of feedback. Several factors contribute to this. There is the tendency of the I_C/V_b non-linearity of the characteristics of the output transistors to cancel, because during the part of the cycle in which one transistor is approaching cut-off the other is turned full on. There is a measure of internal feedback around the loop Tr_1, Tr_2, Tr_3 because of the effect which the base impedance characteristics of Tr_1 have on the output current of Tr_3 . Also, the driver transistor Tr_3 , which has to deliver a large voltage swing, is operated under conditions which favour low harmonic distortion—low output load impedance, high input impedance.

A practical power amplifier circuit using this type of output stage is shown in Fig. 3.

The open loop gain of the circuit is approximately 600 with typical transistors. The closed loop gain is determined, at frequencies high enough for the impedance of C_3 to be small in comparison to R_4 , by the ratio $(R_3 + R_4)/R_4$. With the values indicated in Fig. 3, this is 13. This gives a feedback factor of some 34dB, and an output impedance of about 160 milliohms.

Since the circuit has unity gain at d.c., because of the inclusion of C_3 in the feedback loop, the output voltage, V_e , is held at the same potential as the base of Tr_4 plus the base emitter potential of Tr_4 and the small potential drop along R_3 due to the emitter current of this transistor. Since the output transistor Tr_1 will turn on as much current as is necessary to pull V_e down to this value, the resistor R_2 , which together with R_1 controls the collector current of Tr_2 , can be used to set the static current of the amplifier output stages. It will also be apparent that V_e can be set to any desired value by small adjustments to R_3 or R_6 . The optimum performance will be obtained when this is equal to half the supply voltage. (Half a volt or so either way will make only a small difference to the maximum output power obtainable, and to the other characteristics of the amplifier, so there is no need for great precision in setting this.)

Silicon planar transistors are used throughout, and this gives good thermal stability and a low noise level. Also, since there is no requirement for complementary symmetry, all the power stages can use n-p-n transistors which offer, in silicon, the best performance and lowest cost. The overall performance at an output level of 10 watts, or any lower level, more than meets the standards laid down by Williamson. The power output and gain/frequency graphs are shown in Figs. 4-6, and the relationship between output power and total harmonic distortion is shown in Fig. 7. Since the amplifier is a straight-forward class A circuit, the distortion decreases linearly with output voltage. (This would not necessarily be the case in a class B system if any significant amount of cross-over distortion was present.) The analysis of distortion components at levels of the order of 0.05% is difficult, but it appears that the residual distortion below the level at which clipping begins is predominantly second harmonic.

Stability, power output and load impedance

Silicon planar n-p-n transistors have, in general, excellent high frequency characteristics, and these contribute to the very good stability of the amplifier with reactive loads. The author has not yet found any combination of L and C which makes the system unstable, although the system will readily become oscillatory with an inductive load if R_3 is shunted by a small condenser to cause roll-off at high frequencies.

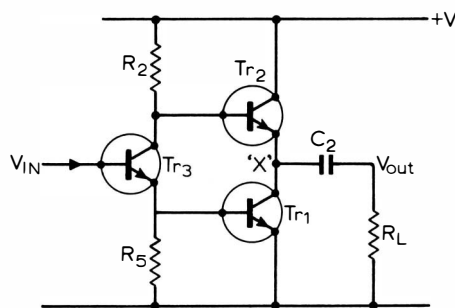

Fig. 2. Arrangement for push-pull drive of class A stage.

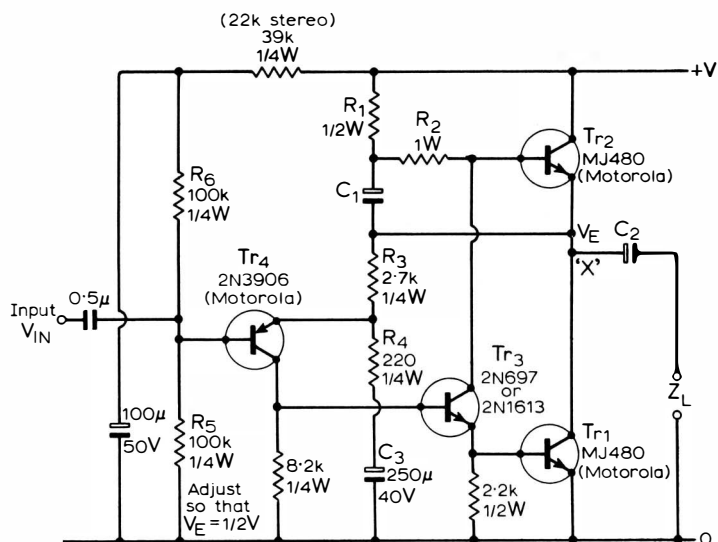

Fig. 3. Practical power amplifier circuit.

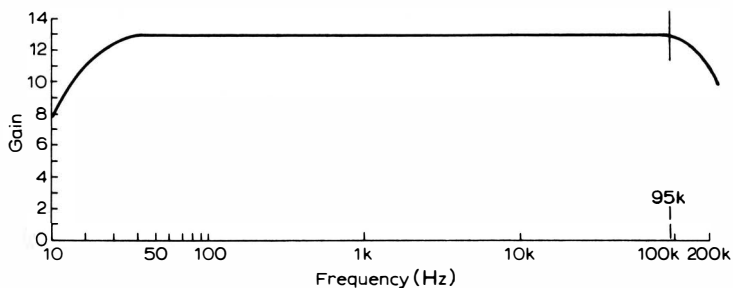

Fig. 4. Gain/frequency response curve of amplifier.

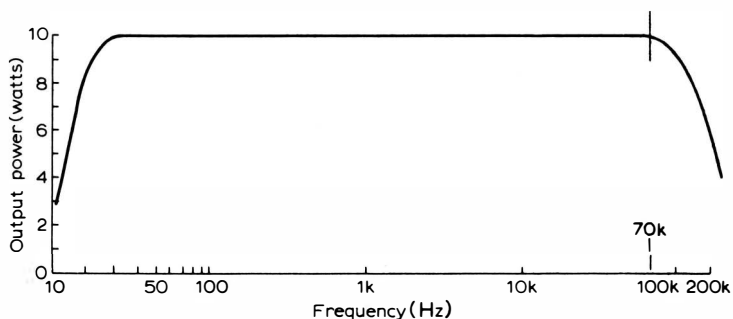

Fig. 5. Output power/frequency response curve of amplifier.

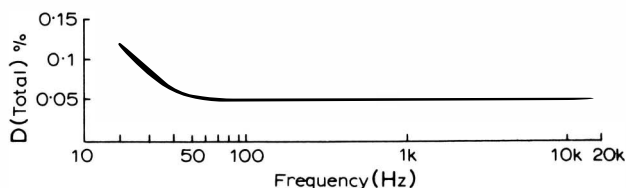
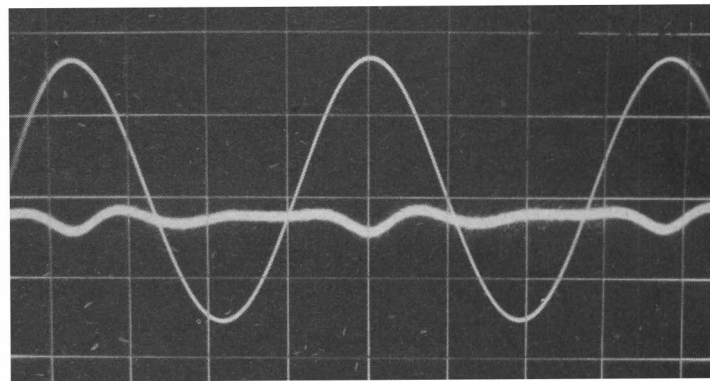
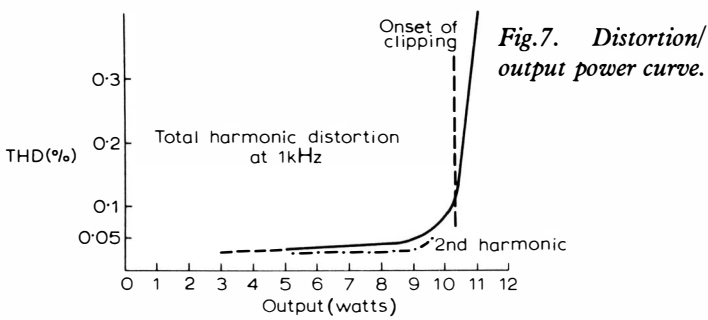

Fig. 6. Distortion/frequency curve at 9W.



Sine wave performance at 1kHz. 9 watts, 15 ohm resistive load. Fundamental on scale of 10V/cm. Distortion components on scale of 50mV/cm with r.m.s. value of 0.05%.

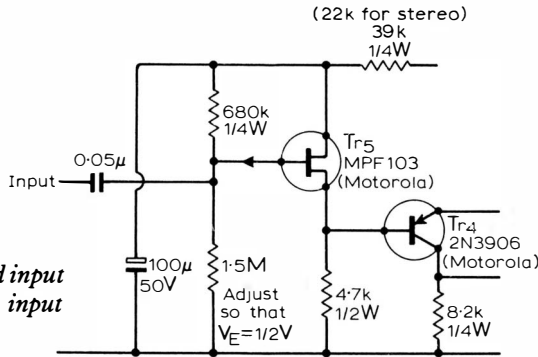

Fig.8. Modified input circuit for high input impedance.

The circuit shown in Fig. 3 may be used, with very little modification to the component values, to drive load impedances in the range 3-15 ohms. However, the chosen output power is represented by a different current/voltage relationship in each case, and the current through the output transistors and the output-voltage swing will therefore also be different. The peak-voltage swing and the mean output current can be calculated quite simply from the well-known relationships $W=I^2R$ and $V=IR$, where the symbols have their customary significance. (It should be remembered, however, that the calculation of output power is based on r.m.s. values of current and voltage, that these must be multiplied by 1.414 to obtain the peak values, and that the voltage swing measured is the peak-to-peak voltage, which is twice the peak value.)

When these calculations have been made, the peak-to-peak voltage swing for 10 watts power into a 15-ohm load is found to be 34.8 volts. Since the two output transistors bottom at about 0.6 volt each, the power supply must provide a minimum of 36 volts in order to allow this output. For loads of 8 and 3 ohms, the minimum h.t. line voltage must be 27V and 17 volts respectively. The necessary minimum currents are 0.9, 1.2 and 2.0 amps. Suggested component values for operation with these load impedances are shown in Table 1. C_3 and C_1 together influence the voltage and power roll-off at low audio frequencies. These can be increased in value if a better low-frequency performance is desired than that shown in Figs. 4-6.

Since the supply voltages and output currents involved lead to dissipations of the order of 17 watts in each output transistor, and since it is undesirable (for component longevity) to permit high operating temperatures, adequate heat sink area must be provided for each transistor. A pair of separately mounted 5in x 4in finned heat sinks is suggested. This is, unfortunately, the penalty which must be paid for class A operation. For supplies above 30V Tr_1 and Tr_2 should be MJ481s and Tr_3 a 2N1613.

Table 1. Summary of component combinations for different load impedances.

Z_L	V	I	R_1	R_2	C_1	C_2	V_{IN} (r.m.s.)
3Ω	17V	2A	47Ω	180Ω	500μ	25V 5000μ	25V 0.41V
8Ω	27V	1.2A	100Ω	560Ω	250μ	40V 2500μ	50V 0.66V
15Ω	36V	0.9	150Ω	1.2kΩ	250μ	40V 2500μ	50V 0.9V

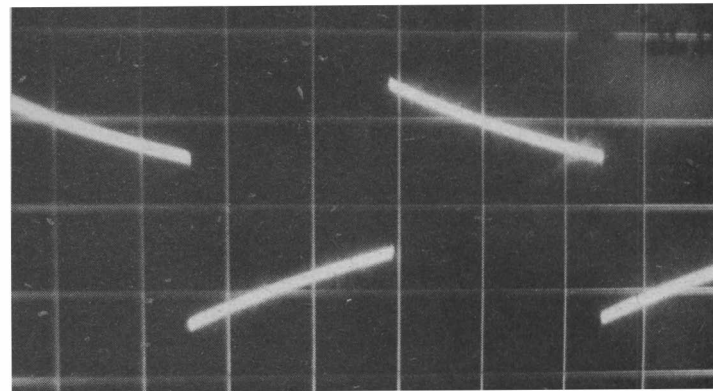

Square wave response at 50Hz.

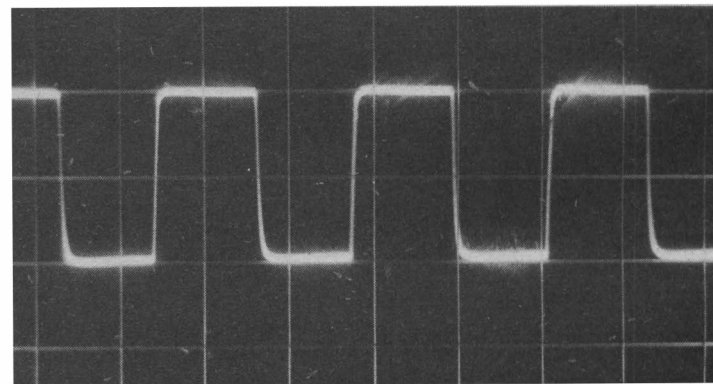

Square wave response. Scale 10V/cm. Frequency 50kHz. 15 ohm resistive load.

If the output impedance of the pre-amplifier is more than a few thousand ohms, the input stage of the amplifier should be modified to include a simple f.e.t. source follower circuit, as shown in Fig. 8. This increases the harmonic distortion to about 0.12%, and is therefore (theoretically) a less attractive solution than a better pre-amplifier.

A high frequency roll-off can then be obtained, if necessary, by connecting a small capacitor between the gate of the f.e.t. and the negative (earthly) line.

Suitable transistors

Some experiments were made to determine the extent to which the circuit performance was influenced by the type and current gain of the transistors used. As expected the best performance was obtained when high-gain transistors were used, and when the output stage used a matched pair. No adequate substitute

is known for the 2N697/2N1613 type used in the driver stage, but examples of this transistor type from three different manufacturers were used with apparently identical results. Similarly, the use of alternative types of input transistor produced no apparent performance change, and the Texas Instruments 2N4058 is fully interchangeable with the Motorola 2N3906 used in the prototype.

The most noteworthy performance changes were found in the current gain characteristics of the output transistor pair, and for the lowest possible distortion with any pair, the voltage at the point from which the loudspeaker is fed should be adjusted so that it is within 0.25 volt of half the supply line potential. The other results are summarized in Table 2.

The transistors used in these experiments were Motorola MJ480/481, with the exception of (6), in which Texas 2S034 devices were tried. The main conclusion which can be drawn from this is that the type of transistor used may not be very important, but that if there are differences in the current gains of the output transistors, it is necessary that the device with the higher gain shall be used in the position of Tr_1 .

When distortion components were found prior to the onset of waveform clipping, these were almost wholly due to the presence of second harmonics.

Constructional notes

Amplifier. The components necessary for a 10 + 10 watt stereo amplifier pair can conveniently be assembled on a standard "Lektrokit" 4in x 4½in s.r.b.p. pin board, as shown in the photographs, with the four power transistors mounted on external heat sinks. Except where noted the values of components do not appear to be particularly critical, and 10% tolerance resistors can certainly be used without ill effect. The lowest noise levels will however be obtained with good quality components, and with carbon-film, or metal-oxide, resistors.

Power supply. A suggested form of power supply unit is shown in Fig. 9 (a). Since the current demand of the amplifier is substantially constant, a series transistor smoothing circuit can be used in which the power supply output voltage may be adjusted by choice of the base current input provided by the

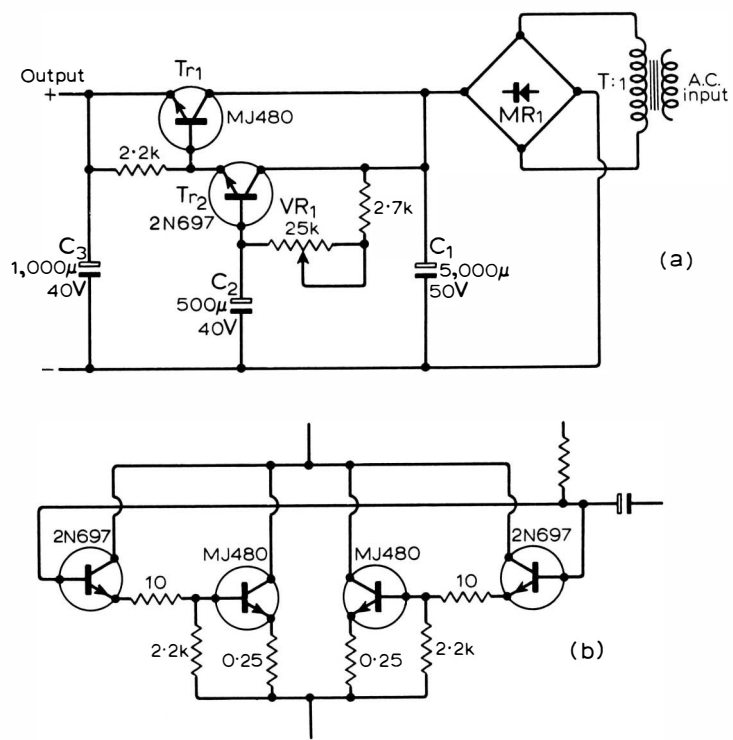

Fig.9. (a) Power supply unit, and (b) parallel connected transistors for high currents.

emitter follower Tr_2 and the potentiometer VR_1 . With the values of reservoir capacitor shown in Table 3, the ripple level will be less than 10mV at the rated output current, provided that the current gain of the series transistors is greater than 40. For output currents up to 2.5 amps, the series transistors indicated will be adequate, provided that they are mounted on heat sinks appropriate to their loading.

However, at the current levels necessary for operation of the 3-ohm version of the amplifier as a stereo pair, a single MJ480 will no longer be adequate, and either a more suitable series transistor must be used, such as the Mullard BDY20, with for example a 2N1711 as Tr_2 , or with a parallel connected arrangement as shown in Fig. 9(b).

The total resistance in the rectifier "primary" circuit, including the transformer secondary winding, must not be less than 0.25Ω. When the power supply, with or without an amplifier, is to be used with an r.f. amplifier-tuner unit, it may be necessary to add a 0.25µF (160V.w.) capacitor across the secondary winding of T_1 to prevent transient radiation. The rectifier diodes specified are International Rectifier potted-bridge types.

Table 2. Relation of distortion to gain-matching in the output stage.

	Current gain (Tr_1)	Current gain (Tr_2)	Distortion (at 9 watts)
1.	135	135	0.06%
2.	40	120	0.4%
3.	120	40	0.12% (pair 2 reversed in position)
4.	120	100	0.09%
5.	100	120	0.18% (pair 5 reversed)
6.	50	40	0.1%

Table 3. Power-supply components.

AMPZ _L	I _{OUT}	V _{OUT}	C ₁	Tr _{1/2}	MR1	T ₁
15Ω	1A	37V	1000µ 50V	MJ480 2N697	5B05	40V 1A
2x 15Ω	2A	37V	5000µ 50V	MJ480 2N697	5B05	40V 2A
8Ω	1.25A	27V	2000µ 40V	MJ480 2N697	5B05	30V 1.25A
2x 8Ω	2.5A	27V	5000µ 40V	MJ480 2N697	5B05	30V 2.5A
3Ω	1.9A	18V	5000µ 30V	MJ480 2N697	5B05	20V 2A
2x 3Ω	3.8A	18V	10,000µ 30V	MJ480 2x2N697	7B05T	20V 4A

Transistor protection circuit

The current which flows in the output transistor chain (Tr_1 , Tr_2) is determined by the potential across Tr_2 , the values of R_1 and R_2 , and the current gain and collector-base leakage current of Tr_2 . Since both of these transistor characteristics are temperature dependent the output series current will increase somewhat with the temperature of Tr_2 . If the amplifier is to be operated under conditions of high ambient temperature, or if for some reason it is not practicable to provide an adequate area of heat-sink for the output transistors, it will be desirable to provide some alternative means for the control of the output transistor circuit current. This can be done by means of the circuit shown in Fig. 10. In this, some proportion of the d.c. bias current to Tr_1 is shunted to the negative line through Tr_7 , when the total current flowing causes the potential applied to the base of Tr_6 to exceed the turn-on value (about

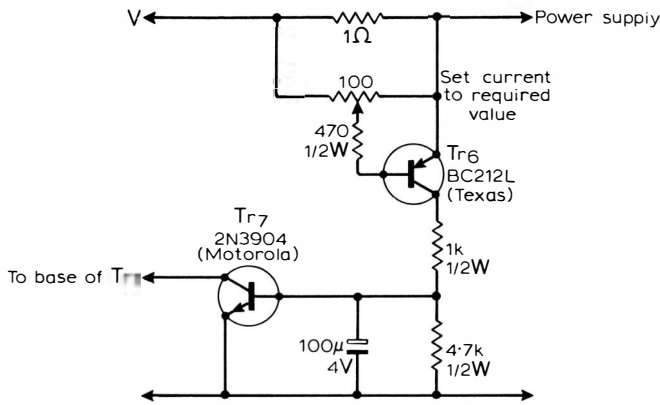

Fig.10. Amplifier current regulation circuit.

0.5 volt). This allows very precise control of the series current without affecting the output power or distortion characteristics. The simpler arrangement whereby the current control potential for Tr_7 is obtained from a series resistor in the emitter circuit of Tr_1 leads, unfortunately, to a worsening of the distortion characteristics to about 0.15% at 8 watts, rising to about 0.3% at the onset of overload.

Performance under listening conditions

It would be convenient if the performance of an audio amplifier (or loudspeaker or any other similar piece of audio equipment) could be completely specified by frequency response and harmonic distortion characteristics. Unfortunately, it is not possible to simulate under laboratory conditions the complex loads or intricate waveform structures presented to the amplifier when a loudspeaker system is employed to reproduce the everyday sounds of speech and music; so that although the square wave and low-distortion sine wave oscillators, the oscilloscope, and the harmonic distortion analyser are valuable tools in the design of audio circuits, the ultimate test of the final design must be the critical judgment of the listener under the most carefully chosen conditions his facilities and environment allow.

The possession of a good standard of reference is a great help in comparative trials of this nature, and the author has been fortunate in the possession, for many years, of a carefully and expensively built "Williamson" amplifier, the performance of which has proved, in listening trials, to equal or exceed, by greater or lesser margins, that of any other audio amplifier with which the author has been able to make comparisons.

However, in the past, when these tests were made for personal curiosity, and some few minutes could elapse in the transfer of input and output leads from one amplifier to the other, the comparative performance of some designs has been so close that the conclusion drawn was that there was really very little to choose between them. Some of the recent transistor power amplifier circuits gave a performance which seemed fully equal to that of the "Williamson", at least so far as one could remember during the interval between one trial and the next. It was, however, appreciated that this did not really offer the best conditions for a proper appraisal of the more subtle differences in the performance of already good designs, so a changeover switch was arranged to transfer inputs and outputs between any chosen pair of amplifiers, and a total of six amplifier units was assembled, including the "Williamson", and another popular valve unit, three class B transistor designs, including one of commercial origin, and the class A circuit described above. The frequency response, and total harmonic distortion characteristics, of the four transistor amplifiers was tested in the laboratory prior to this trial, and all were found to

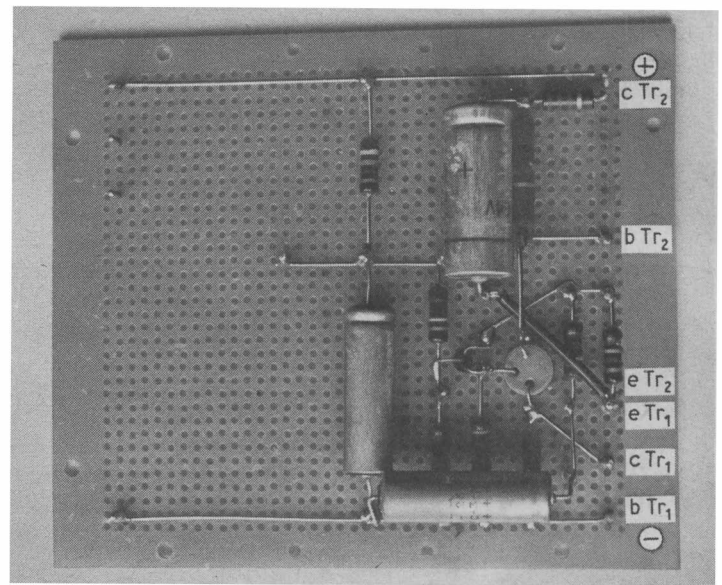

Layout of single channel of 10+10 watt amplifier on standard 4in \times 4 $\frac{3}{4}$ in 'Lektrokit' s.r.b.p. pin board.

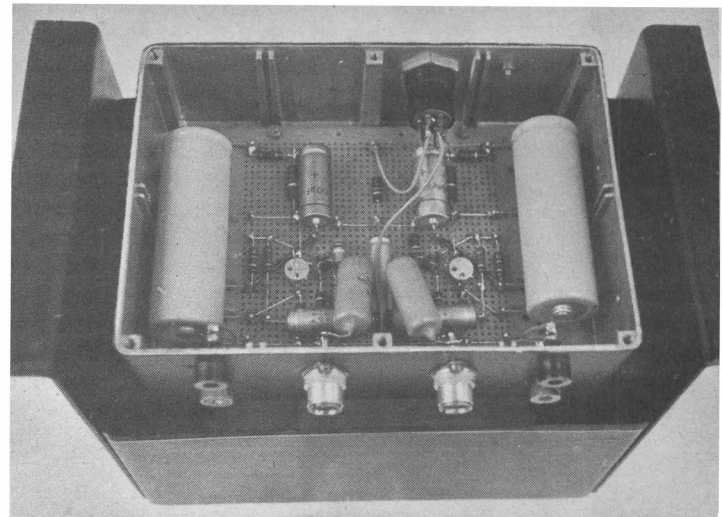

Underside of completed amplifier, with base cover removed, showing external box-form heat sink.

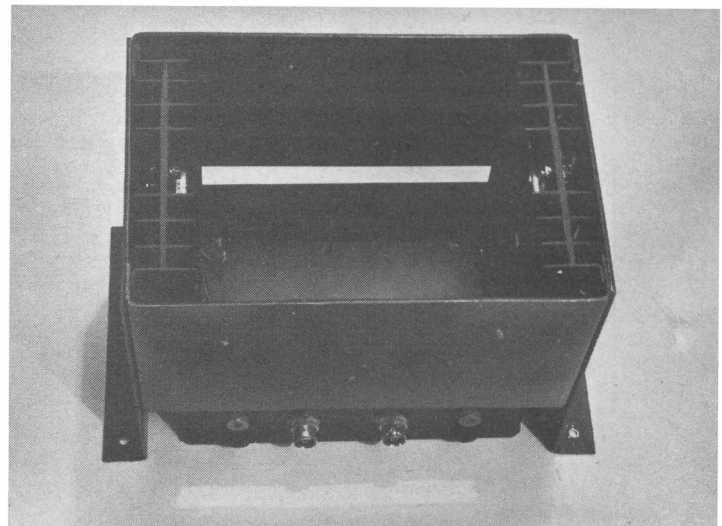

Looking down on the completed amplifier.

have a flat frequency response through the usable audio spectrum, coupled with low harmonic distortion content (the worst-case figure was 0.15%).

In view of these prior tests, it was not expected that there would be any significant difference in the audible performance of any of the transistor designs, or between them and the valve amplifiers. It was therefore surprising to discover, in the event, that there were discernible differences between the valve and the three class B transistor units. In fact, the two valve designs and the class A transistor circuit, and the three class B designs formed two tonally distinct groups, with closely similar characteristics within each group. The "Williamson" and the present class A design were both better than the other valve amplifier, and so close in performance that it was almost impossible to tell which of the two was in use without looking at the switch position. In the upper reaches of the treble spectrum the transistor amplifier has perhaps a slight advantage.

The performance differences between the class A and the class B groups were, however, much more prominent. Not only did the class A systems have a complete freedom from the slight "edginess" found on some high string notes with all the class B units, but they appeared also to give a fuller, "rounder", quality, the attractiveness of which to the author much outweighs the incidental inconvenience of the need for more substantial power supply equipment and more massive heat sinks.

Some thought, in discussions with interested friends, has been given to the implications of this unlooked-for discovery, and a tentative theory has been evolved which is offered for what it is worth. It is postulated that these tonal differences arise because the normal moving-coil loudspeaker, in its associated housing, can present a very complex reactive load at frequencies associated with structural resonances, and that this might provoke transient overshoot when used with a class B amplifier, when a point of inflection in the applied waveform chanced to coincide with the point of transistor crossover, at which point, because of the abrupt change in the input parameters of the output transistors the loop stability margins and output damping will be less good. In these circumstances, the desired function of the power-amplifier output circuit in damping out the cone-response irregularities of the speaker may be performed worse at the very places in the loudspeaker frequency-response curve where the damping is most needed.

It should be emphasized that the differences observed in these experiments are small, and unlikely to be noticed except in direct side-by-side comparison. The perfectionist may, however, prefer class A to class B in transistor circuitry if he can get adequate output power for his needs that way.

Listener fatigue

In the experience of the author, the performance of most well-designed audio power amplifiers is really very good, and the differences between one design and another are likely to be small in comparison with the differences between alternative loudspeaker systems, for example, and of the transistor designs so far encountered, not one could be considered as displeasing to the ear. However, with the growing use of solid-state power amplifiers, puzzling tales of "listener fatigue" have been heard among the *cognoscenti*, as something which all but the most expensive transistor amplifiers will cause the listener, in contradistinction with good valve-operated amplifiers. This seemed to be worth investigation, to discover whether there was any foundation for this allegation.

In practice it was found that an amplifier with an impeccable performance on paper could be quite worrying to listen to under certain conditions. This appears to arise and be particularly associated with transistor power amplifiers because most of these are easily able to deliver large amounts of power at supersonic frequencies, which the speakers in a high quality

system will endeavour to present to the listener. In this context it should be remembered that in an amplifier which has a flat power response from 30Hz to 180kHz, 90% of this power spectrum will be supersonic.

This unwanted output can arise in two ways. It can be because of wide spectrum "white noise" from a preamplifier with a significant amount of hiss—this can happen if a valve preamplifier is mismatched into the few thousand ohms input impedance of a transistor power amplifier, and will also cause the system performance to be unnaturally lacking in bass. Trouble of this type can also arise if transient instability or high frequency "ringing" occurs, for example when a reactive load is used with a class B amplifier having poor cross-over point stability.

REFERENCE

1. Bailey, A.R., "High-performance Transistor Amplifier", *Wireless World*, November 1966; "30-Watt High Fidelity Amplifier", May 1968; and "Output Transistor Protection in A.F. Amplifiers", June 1968.

Conferences and Exhibitions

- | | |
|--|--------------------|
| LONDON | |
| Apr. 21-25 | Savoy Place |
| Switching Techniques for Telecommunication Networks | |
| (I.E.E., Savoy Pl., London W.C.2) | |
| Apr. 22-30 | Olympia |
| Engineering and Marine Exhibition | |
| (F. W. Bridges & Sons, Commonwealth House, New Oxford St., London W.C.1) | |
| EXETER | |
| Apr. 1 & 2 | The University |
| Applications of R.F. Spectroscopy to the Electronic Structure of Solids | |
| (Dr. J. E. Cousins, The University, Exeter) | |
| KINGSTON-ON-THAMES | |
| Apr. 1 & 2 | Col. of Technology |
| Digital Storage Techniques | |
| (Dr. R. V. Sharman, College of Technology, Penrhyn Rd., Kingston-on-Thames) | |
| SOUTHAMPTON | |
| Apr. 15-18 | The University |
| Computer Aided Design | |
| (I.E.E., Savoy Pl., London W.C.2) | |
| YORK | |
| Apr. 16-18 | The University |
| Thin Films Conference | |
| (I.P.S.S., 47 Belgrave Sq., London S.W.1) | |
| OVERSEAS | |
| Apr. 8-10 | New York |
| Computer Processing in Communications | |
| (Polytechnic Inst. of Brooklyn, 333 Jay St., Brooklyn, N.Y. 10021) | |
| Apr. 11-14 | Munich |
| Semiconductor Device Research | |
| (Dr. H. H. Burghoff, VDE Haus, Stresemann Allee 21, 6 Frankfurt am Main) | |
| Apr. 15-18 | Amsterdam |
| Magnetics Conference | |
| (Dr. Th. Holtwijk, Philips Research Laboratories, Eindhoven, Netherlands) | |
| Apr. 16-18 | Washington |
| Geoscience Electronics | |
| (I.E.E.E., 345 E.47th St., New York, N.Y. 10017) | |
| Apr. 19 & 20 | Armentieres |
| Amateur Television Congress | |
| (Club Francais de Television d'Amateur, 13 rue de Bellevue, Paris 19) | |
| Apr. 21 & 22 | Austin |
| Circuit Theory Symposium | |
| (University of Texas, Austin, Texas) | |
| Apr. 22-24 | Washington |
| Telemetry Conference | |
| (I.E.E.E., 345 E.47th St., New York, N.Y. 10017) | |
| Apr. 23-25 | Lexington |
| Electronic Crime Countermeasures | |
| (J. S. Jackson, College of Engineering, University of Kentucky, Lexington) | |
| Apr. 30-May 2 | Washington |
| Electronic Components Conference | |
| (I.E.E.E., 345 E.47th St., New York, N.Y. 10017) | |