

Low-cost 15-W Amplifier

A directly coupled design with a symmetrical output stage and a differential amplifier input

by Ian Hardcastle* and Basil Lane

The transistors used in this amplifier are from the Silect range produced by Texas Instruments—devices with a plastic encapsulation. The complete circuit employs only five capacitors and can be built for about £5.

Circuit operation

Fig.1 shows a diagram of the amplifier circuit. Transistors Tr_1 and Tr_2 , arranged as a long-tailed pair, form the input stage. The use of this type of circuit brings a number of advantages over the more conventional arrangements. Assuming a temperature change in Tr_1 is matched by a similar temperature change in Tr_2 , and that they are both the same type of transistor, then the V_{BE} of each will be changed by a similar amount. Since an error signal can only be produced when there is a difference in the two potentials, this configuration is characteristically more stable than a single transistor.

The virtue of a differential signal at the two bases producing a suitable output also results in the possibility of feeding the source signal to Tr_1 base, and a feedback signal to Tr_2 base, thus separating these two signal paths, and avoiding the dependence of a.c. closed loop gain on source impedance at the amplifier input.

In a similar fashion, the d.c. stability of the quiescent voltage at the output stage is ensured by applying a large d.c. feedback to Tr_2 .

The potentiometer RV_1 has been included to allow for tolerances in the bias resistor chain.

The quiescent d.c. voltage at the collector of Tr_1 is about 37.5V. Since the pre-driver stage (Tr_3) requires a base potential of around 45V, a zener diode has been selected as the simplest method of giving a suitable d.c. voltage shift whilst minimizing the signal attenuation. There is, however, the slightly alarming side effect of producing a thump in the loudspeaker when the power supply is turned on. Bootstrap feedback is applied to the collector of Tr_3 . The output swings in phase with the collector of Tr_3 but displaced from it by about $\frac{1}{2}V_{CC}$. This constant voltage applied across R_{13} forms a constant current sink and ensures that the minimum collector current of Tr_3 is only one third of its maximum, thus helping to stabilize stage gain.

Of considerable importance is the temperature stability of output quiescent current provided by transistor Tr_4 . Here, RV_2 is used to self bias the transistor, and set the ratio of V_{CE} to V_{BE} to approximately two. As mentioned earlier, the V_{BE}

*Texas Instruments Ltd.

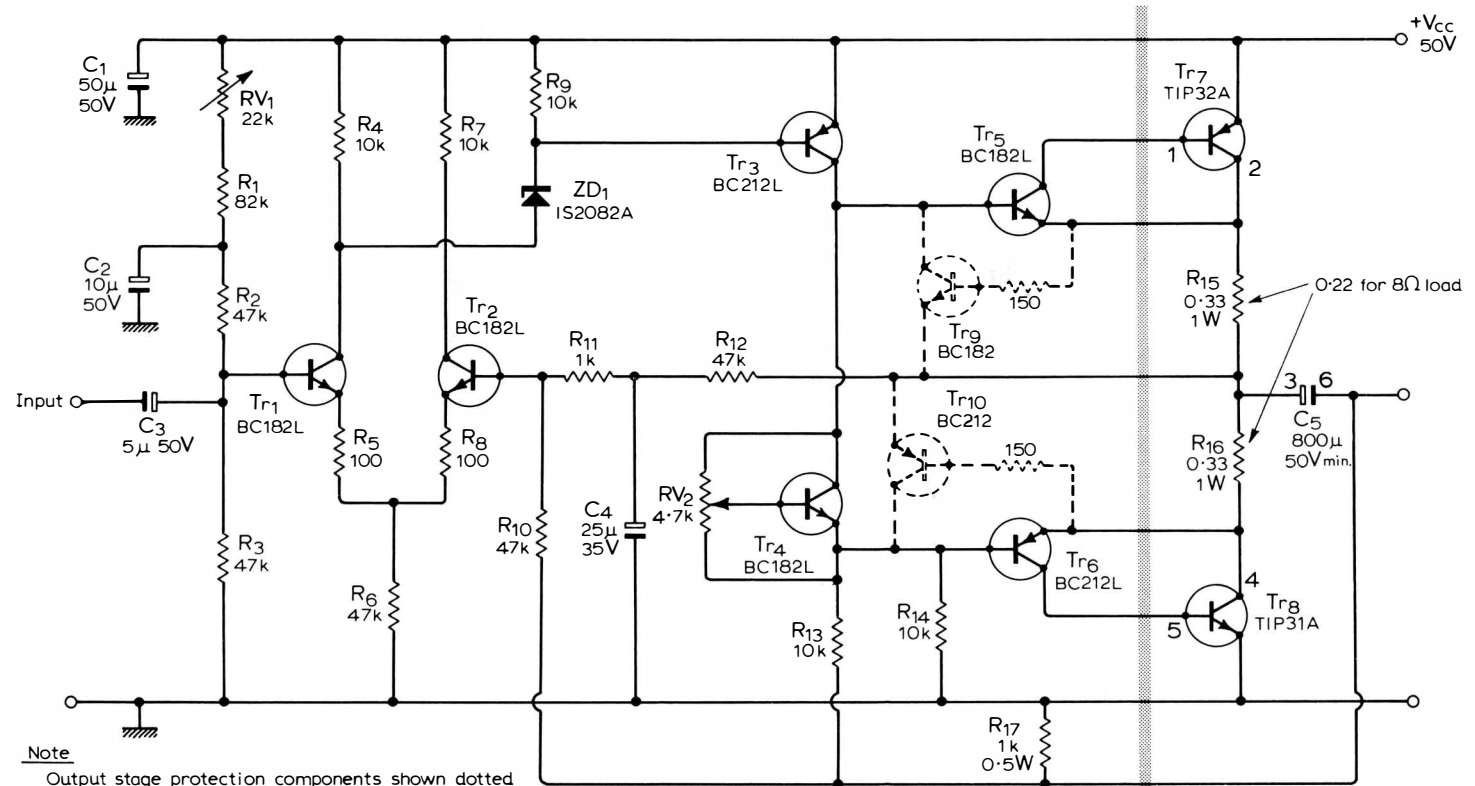

Fig.1 Amplifier circuit for driving resistive and inductive loads of 15Ω or 8Ω

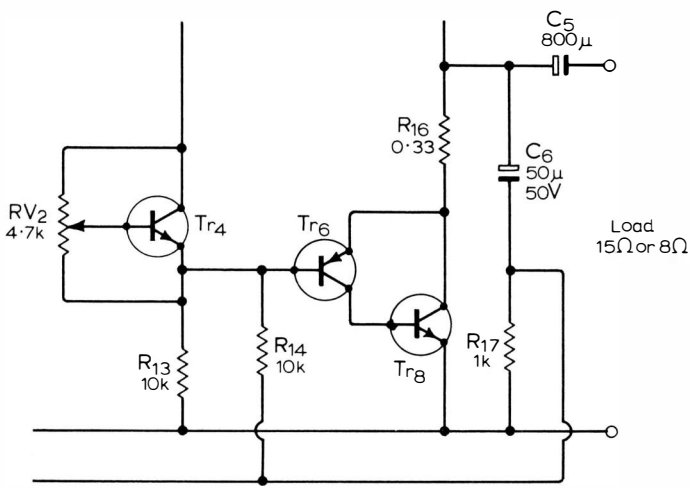

Fig.2 Modified output stage required to drive an electrostatic loudspeaker (capacitive load)

of a transistor is temperature dependent, and any change of V_{BE} in Tr_5 or Tr_6 would result in a rise of the output stage current. If Tr_4 is placed in thermal contact with Tr_5 or Tr_6 , a similar temperature change would result in the V_{BE} of Tr_4 changing and producing approximately double the change in V_{CE} . By this action, the potentials at the bases of the drivers would be moved in a direction to compensate for the variations in both transistors.

The a.c. closed loop gain and the d.c. quiescent voltage on the collectors of the output stage are set by two feedback loops. In the case of the former the loop gain, set at 48, is determined by the divider action of R_{10} and R_{11} —one end of R_{11} being at a.c. earth via C_4 . The d.c. feedback used to define the quiescent d.c. output voltage is set by the combination of the load, R_{10} , R_{11} , and R_{12} , these resistors reducing the output d.c. voltage by a half at the base of Tr_2 . The base potential of Tr_1 is set to a similar value by the bias chain RV_1 , R_1 , R_2 and R_3 . Assume a possible rise in the d.c. output voltage. This is transmitted via the feedback loop to the base of Tr_2 causing a similar rise of potential. The resulting increase of current in the tail resistor R_6 , will cause a corresponding increase in the p.d. developed across it. This will cause a reduction in the difference of potential between the emitter and base of Tr_1 and cause a rise in collector voltage. The current drive to Tr_3 is reduced and this in turn reduces its collector voltage affecting the potentials at the bases of Tr_5 and Tr_6 .

In this fashion compensation occurs for any shift in the d.c. level at the output.

The authors consider that a simple fuse is not an adequate form of output stage protection since the rise of collector current to destruction point can occur much before the fuse blows.

A suitable protection circuit for the amplifier is shown dotted. The collector current flowing in the output stage defines the base potentials of Tr_9 and Tr_{10} . If these voltages should rise, these transistors turn on and cut off the bases of Tr_5 and Tr_6 , thus preventing a further rise in the output current. Fig.2 shows a circuit modification for use with electrostatic speakers.

Construction and setting up

Although other layouts may work perfectly well, possible faults have been reduced to a minimum in the layout of Fig.3. The power supply is fed first to the output stage and then to the amplifier panel.

The size of the heat sink will depend upon the power output which the amplifier will be expected to develop under working conditions. In a domestic situation this will be low and only a small dissipation (approx. 1 watt) would be expected in the output stage. In this case about 4 in. sq. of aluminium would suffice. A finned aluminium heat sink is more suitable for long periods at high power.

Before turning the power supply on for the first time, terminate a suitable load at the output, and set RV_2 to minimum resistance between the collector and base of Tr_4 . Connect a low resistance meter (100mA scale) in series with the emitter of Tr_7 and a suitable 100mA fuse. Switch on the power supply and after the initial surge adjust the quiescent current to 20mA by means of RV_2 . Turn off the supply and permanently reconnect the emitter of Tr_7 to the power supply. With the power switched on and an oscilloscope connected at the load, inject a 1kHz signal at the input at a level sufficient to cause clipping. Potentiometer RV_1 should now be adjusted to produce a symmetrical waveform. The amplifier is now set up and ready for use.

Specifications

With a 15Ω load the maximum power output at clipping is 17.3W. For 15W into 15Ω frequency response is 20Hz–100kHz requiring an input of 312mV (into 20kΩ). Signal-to-noise ratio is 73dB, referred to 312mV at 1kHz. Intermodulation distortion is between 0.021% and 0.073%. Total harmonic distortion for both 15Ω and 8Ω loads is shown in Fig. 4.

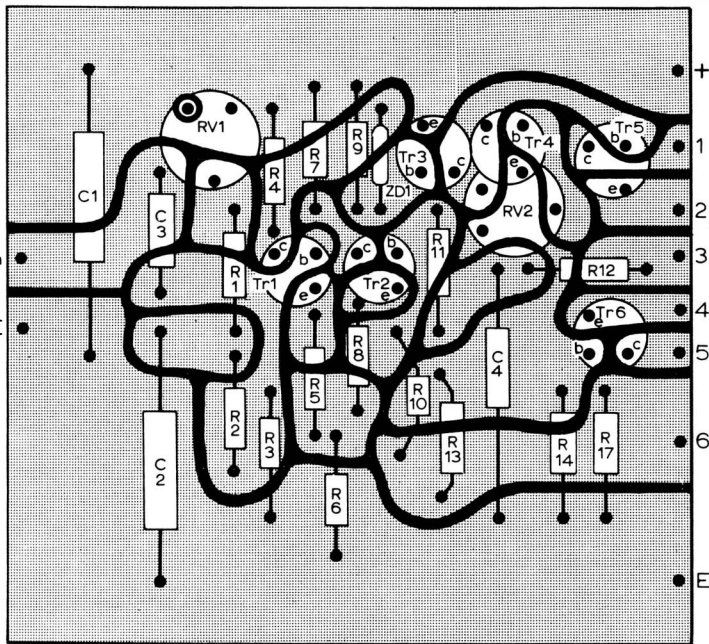

Fig.3 Printed circuit board layout (actual size) for all components except the output transistors and their emitter resistors, and the speaker series capacitor

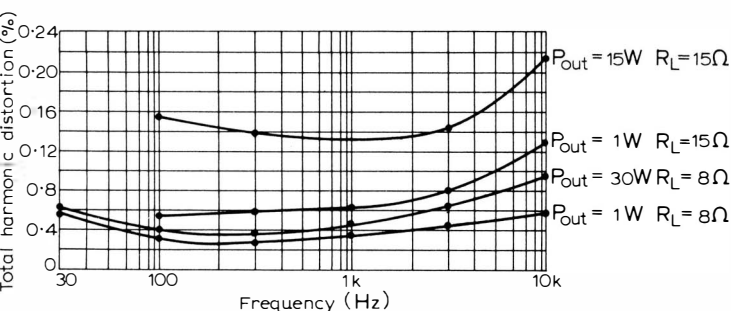

Fig.4 Curves of total harmonic distortion against frequency for different powers and loads