

Figure 22.26 Block diagram illustrating the coding of the left and right channels in the Zenith-GE stereo system

22.26 shows how the left and right signals are coded into a form suitable for modulating the transmitter and Figure 22.27 shows the frequency spectrum of the combined modulating signal. It is found that the  $(L+R)$  signal provides an acceptable mono programme for single-channel mono listeners. The mono receiver does not process the information above 15 kHz and the extra information does not affect mono reception. The  $(L-R)$  information is used to amplitude-modulate a subcarrier which has a frequency of 38 kHz. The subcarrier is suppressed and the sidebands are used for final modulation.

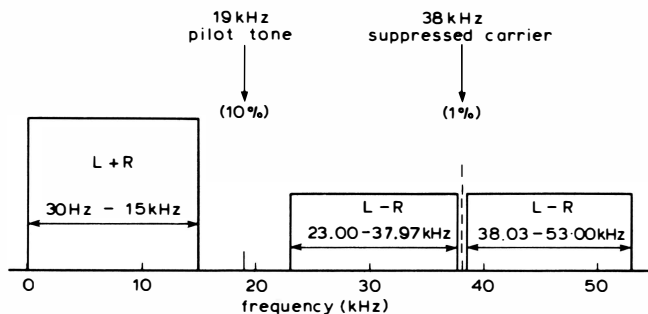

Figure 22.27 Spectrum of coded signal in the Zenith-GE stereo system

A low-level pilot tone on 19 kHz is also transmitted. This is required at the receiver for decoding the stereo information.

At the receiver normal f.m. demodulation produces the output signal shown in *Figure 22.27*. The mono receiver extracts only the  $(L + R)$  signal but the stereo receiver has to process the full spectrum in order to decode the left and right audio signals for transmission through their respective amplifiers and loudspeakers.

The standard mono deviation is  $\pm 75$  kHz but inclusion of the pilot tone in the transmitted signal at a constant level of 10 per cent, reduces the available modulation for signal information to 90 per cent. In this respect the mono listener loses some signal when reproducing a stereo transmission on his mono receiver. The highest frequency involved in stereo is 53 kHz, but the reduced deviation enables a passband of about 240 to 250 kHz to remain adequate—but all of the band is required. The instantaneous deviation of the transmitter frequency is given by:

$$0.9 \left[ \frac{A+B}{2} + \frac{A-B}{2} \sin 2\omega t + 0.1 \sin \omega t \right] \times 75 \text{ kHz}$$

where

$$\begin{aligned} A &= \text{the pre-emphasised left-hand signal} \\ B &= \text{the pre-emphasised right-hand signal} \\ \omega/2\pi &= \text{the pilot-tone frequency of 19 kHz.} \end{aligned}$$

The normalised values of  $A$  and  $B$  are restricted to the range of  $+$  and  $-1$ , and  $(A+B)/2$  represents the compatible signal to which the mono receiver responds.

### Demodulation and decoding

Demodulation of the f.m. signal is generally carried out by means of the ratio detector and, although this type of demodulator has amplitude-limitation characteristics, the preceding i.f. amplifier system is usually operated under amplitude-limiting conditions so that the overall amplitude-limitation is very thorough.

There are several possible methods for decoding the stereo information, and most of them require reconstitution of the 38 kHz subcarrier. This is done by extracting the pilot tone with a simple filter and doubling its frequency or locking a 38 kHz oscillator to it. Incidentally, *Figure 22.27* shows why the pilot tone is transmitted instead of the subcarrier itself. It would be difficult to filter out the subcarrier without attenuating some of the  $(L - R)$  sidebands but it is relatively easy to extract the pilot tone.

One method of decoding would be to filter out the  $(L + R)$  signals, add the subcarrier to the  $(L - R)$  sidebands and amplitude-demodulate the  $(L - R)$  signals. By adding  $(L + R)$  to  $(L - R)$  the left-hand information is obtained; by subtracting  $(L - R)$  from  $(L + R)$  the right-hand signals become available.

Of the many possible methods for decoding, the most widely used system uses the principle shown in *Figure 22.28*. At (a) and (b) are shown right- and left-hand signals respectively; at (c) is shown the subcarrier. If the subcarrier is re-inserted into the demodulated spectrum of *Figure 22.27* the subcarrier takes the form shown in *Figure 22.28(d)*. By using diode rectifiers, one to conduct on positive half-cycles of the subcarrier, and the other to conduct on negative half-cycles, it is seen that the right and left signals become separately available in the rectifier circuits. The subcarrier is now acting as a switch which samples the envelope at 38 kHz.

The precise phase relationship between the pilot tone and the subcarrier must be preserved for maximum isolation between the left and right signals (the transmitter tolerance is within  $\pm 30^\circ$ ) and, to this end, the subcarrier oscillator in the receiver decoder is now generally phase-locked to the pilot tone. The principle is shown in *Figure 22.29*. The oscillator frequency is halved and its phase compared with the pilot tone in a phase discriminator. A control voltage is generated if there is any difference in phase between the two, and this voltage is used to control the oscillator frequency to reduce the error.

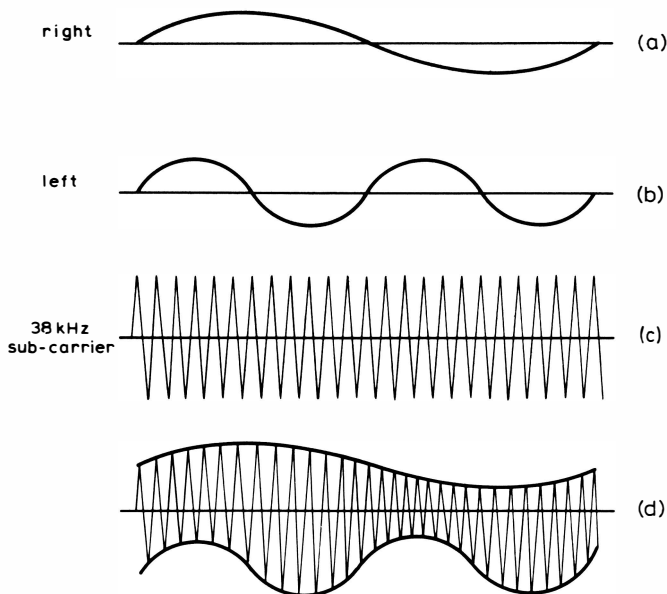

Figure 22.28 Illustrating the principle of one method of decoding the coded stereo signal

Some decoders phase-lock an oscillator which has a frequency of 76 kHz, dividing by four for the phase-lock, and by two to obtain the subcarrier. The philosophy of this system is to minimise errors still further by the process of division.

A complete stereo decoder using the above principles is an ideal circuit application for an i.c. package. Figure 22.30 shows the circuit diagram of such an i.c., and Figure 22.31 shows the external components required for its use. The i.c. provides other facilities than just decoding. Provision is made for lighting an indicator lamp when a stereo signal

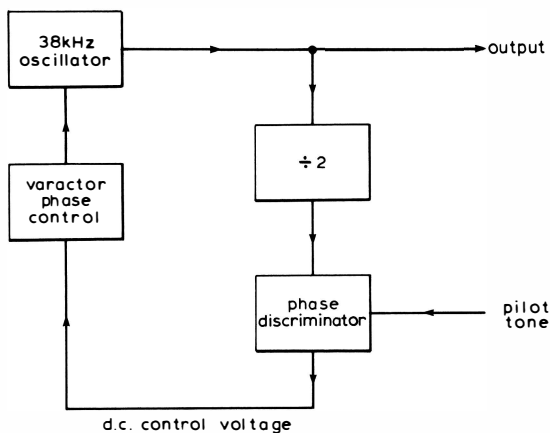

Figure 22.29 Method of phase-locking the 38 kHz local oscillator to the pilot tone