

Most stereo pickups may be used for mono records by joining the two live leads together and connecting as for a mono pickup, but it should be remembered that modern pickups tend to have much lower outputs than the earlier mono types. If a completely separate pickup is used, as distinct from a separate interchangeable head in the same arm, for playing older 78 rpm records. the "live" leads of the two pickups should be switched in a suitably screened unit.

In general, manufacturers' instructions should be followed as to the installation of pickups, except where additional load resistors are specified. All such loads are normally already incorporated in the appropriate Pick-up Adaptor. (See table on page five).

GRAMOPHONE PICKUP ADAPTOR UNIT

This is a small 9 pin plug unit which cannot be inserted incorrectly. It should be plugged into the socket on the rear of the Control Unit.

It has two functions, viz.: (1) to provide a ready means of adapting the equipment for use with literally any gramophone pick-up. and this function is indicated by the numerals in the type number, e.g. R1, M2, etc.; (2) to modify the internal circuit at input No. 1 to provide for either Radio or Microphone, as required. This

function is indicated by the letter prefixing the type number, e.g. R1 or M1, etc.

To choose an adaptor:

For any given pickup the correct adaptor is that which gives a sensitivity equal to the output of the pickup for a recorded velocity of 3cm. per second and presents an impedance approximately equal to or greater than the minimum recommended for that pickup.

Example: A pickup having an output of 5mV /cm/sec (= 15mV for 3cm/sec), and requiring a load of 47K Ω would need the R2 adaptor (16mV and 50K Ω).

It should be noted that where the two outputs of a stereo pickup are joined for mono the load resistance required is halved.

Most pickups normally fall into the following categories:

Low output Magnetic types	R1 or R7
High output Magnetic types	R2
Crystal types	R13
Ceramic types	R2 via corrector network where required, to convert to constant velocity characteristic. See manufacturers' instructions.

Adaptor Unit type	Pickup input sensitivity for 12 watts output	Load Resistance presented by amplifier
R1 or M1)	8 mV.	25,000 ohms
R2 (or M2)	16 mV.	50,000 ohms
R6 (or M6)	5 mV.	10,000 ohms
R7 (or M7)	4 mV.	100,000 ohms
R8 (or M8)	10 mV.	680,000 ohms
R10 (or M10)	100 mV.	100,000 ohms
R12 (or M12)	750 mV.	2.2 M ohms with 100pF in series
R13 (or M13)	300 mV.	1.5 M ohms

RADIO AND MICROPHONE CONNECTIONS

These again are connected to the appropriate sockets as for Gramophone pickups.

The socket marked 2 may be used for a suitable radio tuner unit, while that marked 1 may be adapted for use with either a second tuner or a microphone by choosing the appropriate pickup adaptor unit (see page four).

The QC II imposes a load of 100K ohms across the tuner output.

Sockets not used should be left vacant.

When using Radio Tuner Units the audio lead should be connected before the power supply plug, as the former carries the earth return, which is also HT negative.

A minimum output from the tuner of 0.1 volts rms is required to load the QC II control unit for full output. The optimum is 0.25 volts but if the tuner or recorder gives more than 0.5 volts rms it is desirable that this should be reduced by means of a potentiometer circuit in order to obtain reasonable settings of the volume control.

A wide variety of microphones is suitable for use with the amplifier, since only 1.5mV is required to give full output. The control unit places a load of 100K ohms across the microphone output.

OLDER VERSIONS OF THE EQUIPMENT

This booklet refers to the final version of the QCII control unit and Quad II power amplifier at the time when the QCII was discontinued. Variations to be encountered in earlier versions are as follows:

Control Unit

- (1) below serial no. 4300 three inputs only — no tape facilities. These correspond to inputs 1, 2 and Gram shown in the circuit diagram of drawing 11171 enclosed.
- (2) below serial no. 17000 the record equalisation circuits provided the characteristics shown in table A. At serial no. 17000 these were changed (table B) to provide the then new international LP characteristic (RIAA) on one button, instead of requiring the three righthand buttons to be pressed simultaneously as on the earlier units. A list of equivalent characteristics is shown in table C and the circuit of the earlier units shown in Fig. D.

Power Amplifier

At serial no. 3787 the output transformer was modified. On the older transformers, with tags marked ABC etc., the output was taken via a flying lead connected to :

tag D for 15 ohm output or
tag C for 7 ohm output.

On later transformers marked P Q R etc., the connections are identical and interchangeable but the output is now taken via a fixed lead from tag T and the change of impedance is made by means of links, thus:

for 15 ohm output link tag R to tag S
for 7 ohm output link tag Q to tag R
and tag S to tag T

TABLE A

PRIOR TO SERIAL NUMBER 17000

Push buttons	Reference	t1 μ S	t2 μ S	t3 μ S
○○○●	STD 78	—	636	—
○○●○	ffir 78	25	636	—
○●○○	AES	63.6	400	—
●○○○	COL. LP	100	318	1590
○●●○	NAB	100	318	2240
○●●●	RCA NEW ORTH	75	318	3180
○●○○	NAB — AES Bass — Top	63.6	318	2240

TABLE B
SERIAL NUMBER 17000 & UP

Push buttons	Reference	t1 μ s	t2 μ s	t3 μ s
●○○○	COL. LP	100	318	1590
○●○○	INT. LP	75	318	3180
○○●○	INT. 78	50	450	3180
○○○●	EUR.78	25	636	—
●●○○	NAB	100	318	3180
○○●●	EUR. LP	50	318	2230

TABLE C

Below Serial No. 17000		Serial No. 17000 and above
STD 78		(no equivalent)
ffrr 78	=	EUR 78
AES		(no equivalent)
COL. LP	=	COL. LP
NAB	=	NAB
RCA NEW ORTH	=	INT LP
NAB — AES	=	EUR LP
Bass Top		
(no equivalent)		INT 78

QUAD II CONTROL UNIT

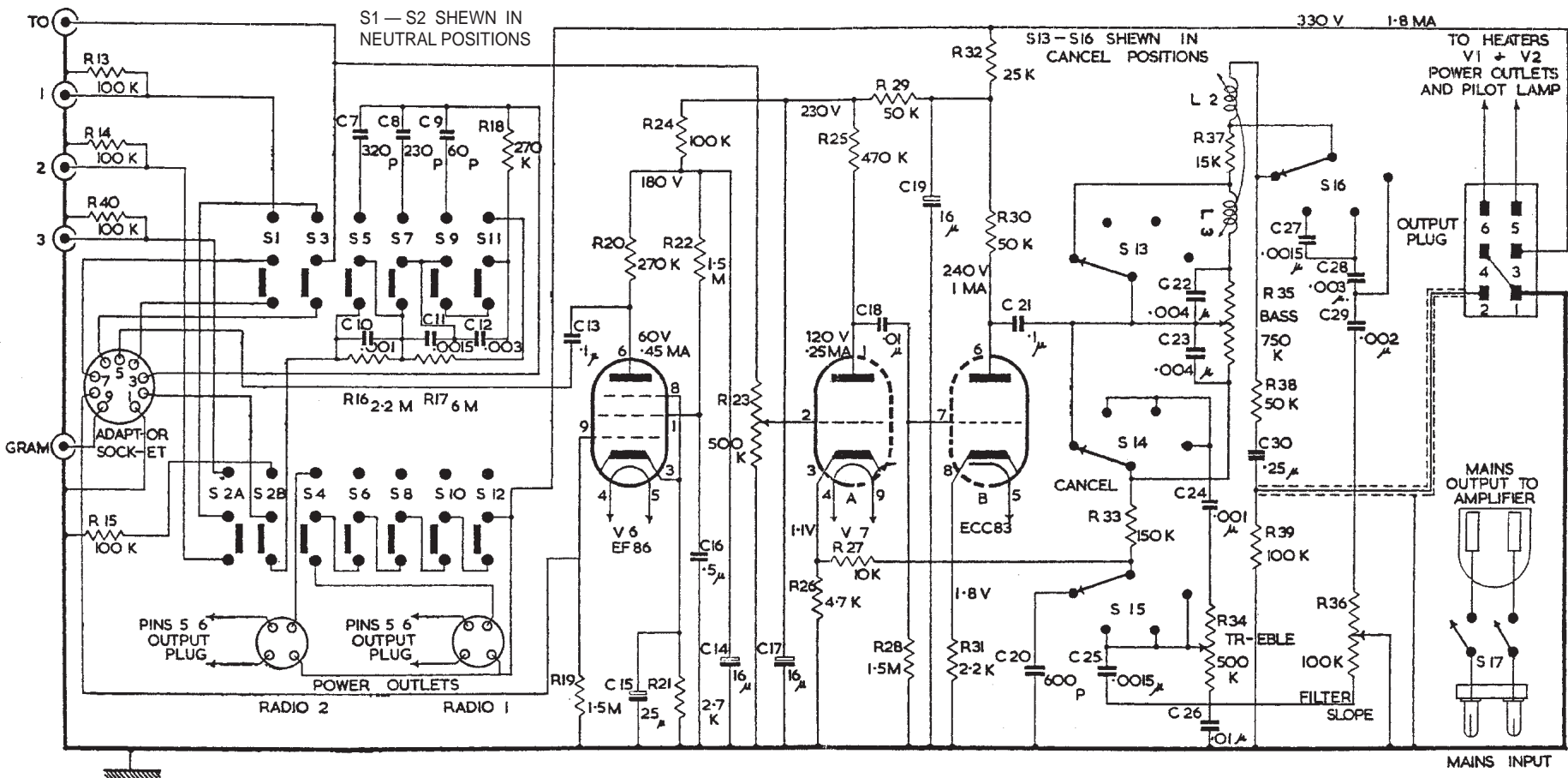

SWITCH GANGING :— S1—S2A—S2B S3—S4 S5—S6 S7—S8 S9—S10 S11—S12 S13—S14—S15—S16

On early models sockets TO and 3 and switch contacts S2A were omitted.

Voltages shewn on this diagram are those actually present and allowances must be made for the loading effect of the voltmeter used when measurements are made

CONTROL UNIT

R	101 102 103	104	105	106	107	108	109	110	111	112	113	114	115	116	117	118	119	120	121	122	123	124	125	126	127	128	129	130
C			101 102 103	104 105	106 107	108	109	110	111	112		113	114	115	116	117 118	119	120	121	122	123	124	125	126	127	128	129	130

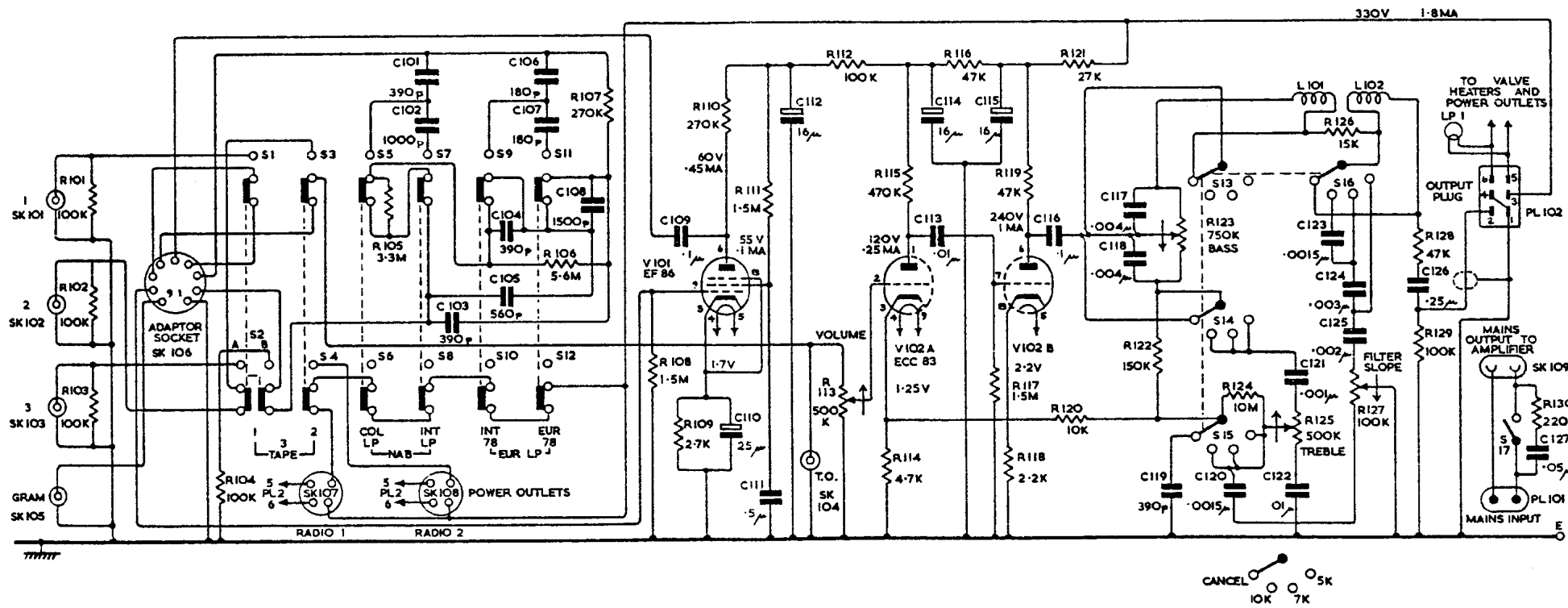

THE VOLTAGE AND CURRENT MEASUREMENTS SHEWN ARE APPROXIMATE AND ARE ONLY PROVIDED AS A GUIDE. ALLOWANCE SHOULD BE MADE FOR THE LOADING EFFECTS OF A VOLTMETER.